

Figure V-9: Illustration of Installing a Floating Turbidity Barrier

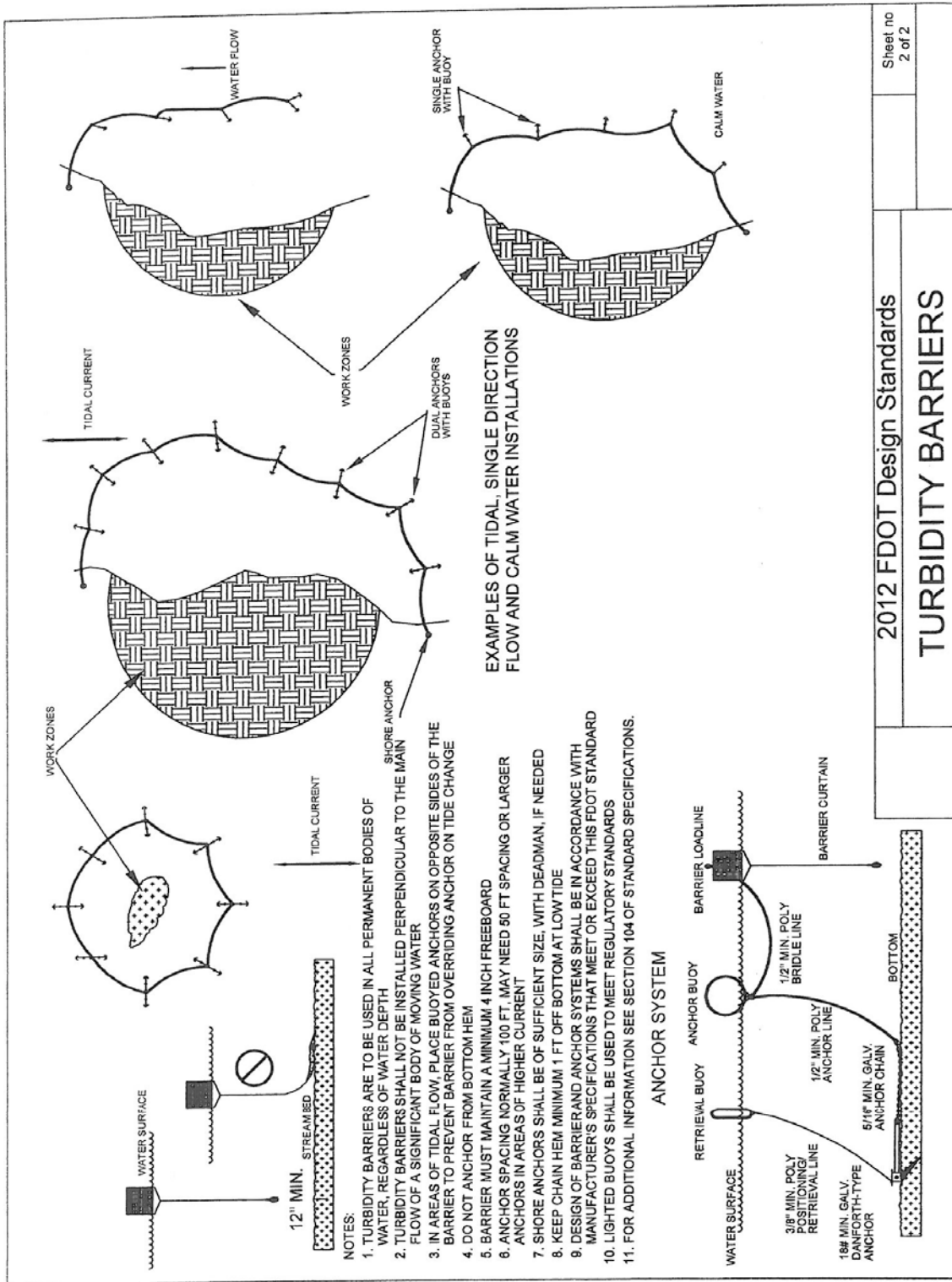

Figure V-10: Illustration of Installing a Floating Turbidity Barrier

Staked Turbidity Barrier (Belted Silt Retention Fence)

WHAT IS ITS PURPOSE?

The BSRF shall be used as a vertical interceptor of sediment transported by overland *sheet flow* on construction sites. The Belted Silt Retention Fence (BSRF) has been designed and tested as a silt fence *system*. The BSRF is a 36-inch wide, spun-bond polyester fabric with an internal scrim. The system encompasses wood stakes and a specific method of attachment (see Installation Specifications in Notes below).

WHERE AND HOW IS IT COMMONLY USED?

- At the toe of cut and fills slopes
- To protect water bodies.
- As a small sediment containment system
- To provide filtering capabilities in slurry conditions

WHEN SHOULD IT BE INSTALLED?

- Before construction activities begin.
- It is designed for control of sheet flow.

WHEN SHOULD IT NOT BE INSTALLED?

- Shall not be installed across streams, ditches, waterways, or anywhere there is concentrated flow.
- Shall not be placed around storm water inlets, which receive concentrate flow.

WHAT NEEDS TO BE INSPECTED?

- Are stakes on the downstream side?
- Does water flow under the fabric?
- Has water flattened the structure?
- Is the fabric torn?
- Is the fabric secured correctly in the ground?
- Is the fabric attached to the posts?
- Will water flow around the fence?
- Has wind destroyed the fence?

WHAT MAINTENANCE ACTIVITIES CAN BE EXPECTED?

- Regular inspection at the end of each workday and after each rainfall event.
- Remove the fence and accumulated sediment and stabilize the exposed area at completion of the project.
- Accumulated sediment should be removed when it reaches half the height of the fence to prevent failures.

NOTES

- As evidenced by a recent study, the BSRF meets the 75% filtration efficiency requirements of the Federal Highway Administration.
- Installation Specifications: The method of installation for the BSRF is an integral part of the system and is unlike any other installation practices. The specifically designed process includes wood (oak) stakes and wood bonding strips at four (4') foot intervals. Stakes that 4 feet high are driven to a depth, which allows 24" of fabric to be above ground. The fabric is then stretched along the inside perimeter of the stakes, pulled tightly and held in place with bonding strips. The bonding strips (typically 1" x 3/8" x 24") are attached to the stake with 1" x 1 1/4" staples. Four staples are used to secure the fabric in place against the 1 1/4" x 1 3/4" wood posts. This installation bonds the fabric and support system (scrim) to the vertical support post. The remaining fabric is now tucked into the trench forming a "J" and when filled with dirt creates a "ground bite". With its firm attachment to each post, the load is now spread to the total linear strength of all the posts within the system.
- *Any variance from the material specifications installation requirements may alter the performance of this product.* The product is available pre-staked to these specifications.

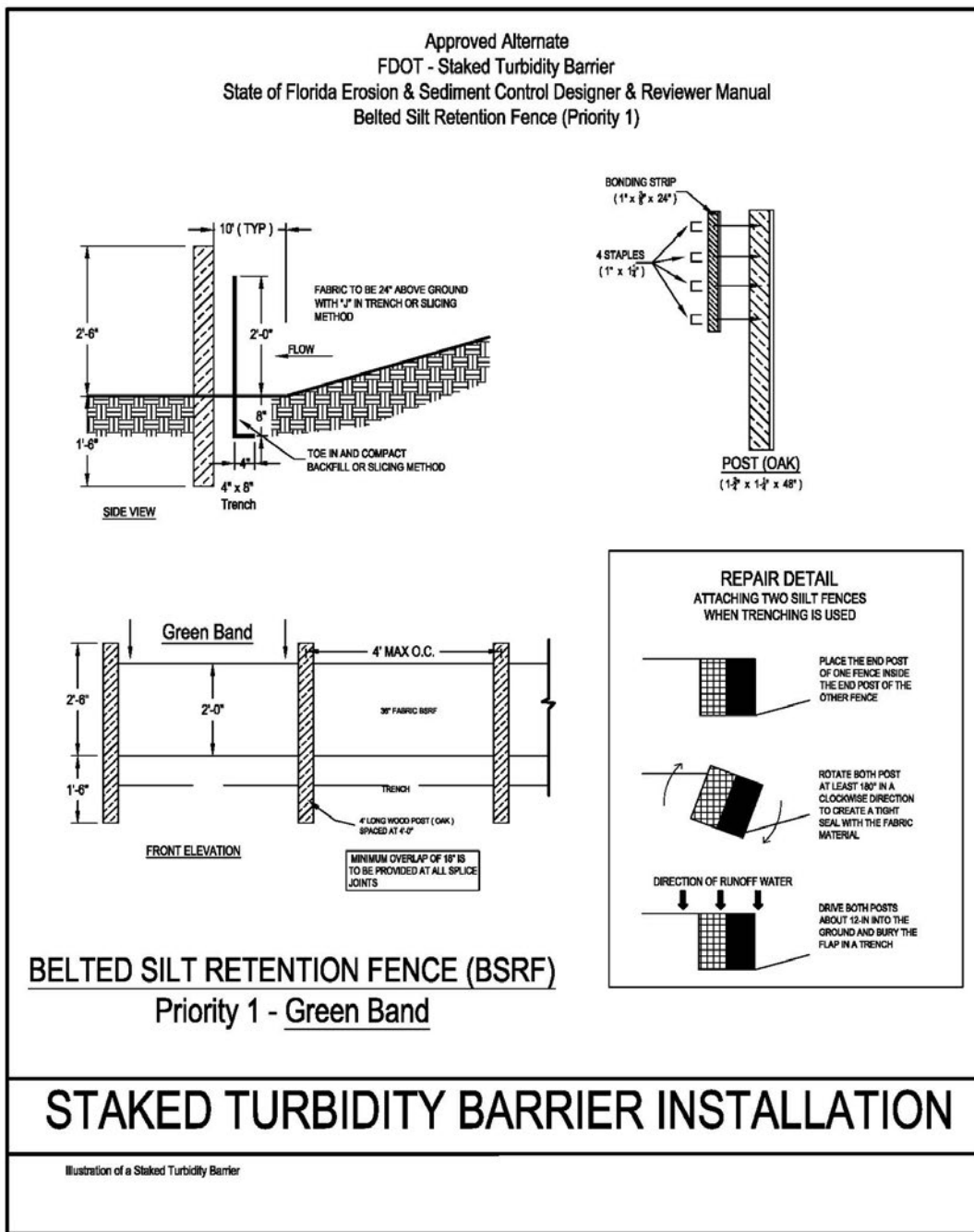

Figure V-11: Illustration of Staked Turbidity Barrier (Belted Silt Retention Fence)

Water Filled Barrier

WHAT IS ITS PURPOSE?

Temporary containment structures that force water away from a construction site as activities occur to create a “dry” working space.

WHERE AND HOW IS IT COMMONLY USED?

- At water embankments.
- As a small cofferdam.
- As small containment systems.
- In streambeds and ponds.
- To create a dry working space.
- To protect water bodies.

WHEN SHOULD IT BE INSTALLED?

- Before construction activities begin.
- While construction activities are occurring.

WHEN SHOULD IT NOT BE INSTALLED?

- Streams where high flows could destroy the barrier.
- After construction activities are completed.

WHAT NEEDS TO BE INSPECTED?

- Is the tube sufficiently filled with water?
- Where and how are captured sediment-laden waters discharged?
- Does the barrier hold water?
- Is water entering the working area?
- Is the construction area stabilized before removing the barrier?
- Have flows destroyed the barrier?

WHAT MAINTENANCE ACTIVITIES CAN BE EXPECTED?

- Repair of the barrier.
- Discharge of waters.
- Removal of accumulated sediment.
- Removal of barrier.

NOTES

- A water-filled barrier provides a temporary work area where extensive amounts of water can be anticipated.
- Sediment-laden waters are to be pumped away from the barrier using a sediment containment filter bag.

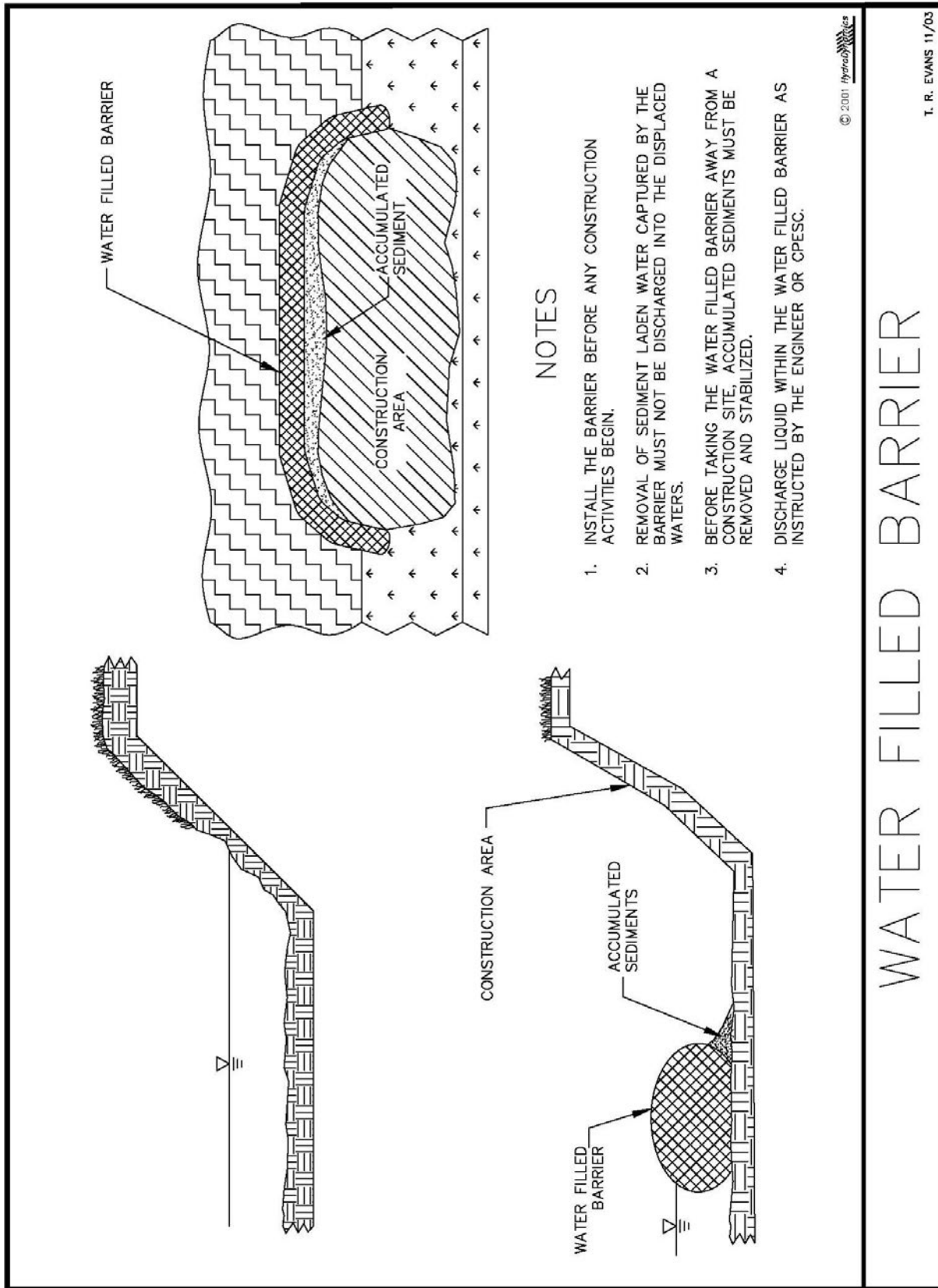

Figure V-12: Illustration of a Water Filled Barrier

Permission is given by HydroDynamics Incorporated to copy and reproduce this detail

Rock Barrier for an Area Drain (a.k.a. Drop, Catch Basin, or Ditch Bottom) Inlet

WHAT IS ITS PURPOSE?

Temporary barriers to cause waters to pond and drain so that sediment can settle out of runoff waters while construction activities occur.

WHERE AND HOW IS IT COMMONLY USED?

- Around median inlets.
- Around inlets to which runoff water flows.

WHEN SHOULD IT BE INSTALLED?

- While construction activities are occurring.
- Only where sump conditions exist.

WHEN SHOULD IT NOT BE INSTALLED?

- After construction activities are completed.
- Where sump conditions do not exist.

WHAT NEEDS TO BE INSPECTED?

- Is at least 1.0-in. diameter rock used?
- Has wire mesh been used?
- Can water flow over the rock?
- Should the rock be replaced?
- Does water flow through the rock?
- Does the rock need "raking?"
- Will water be diverted downstream?

WHAT MAINTENANCE ACTIVITIES CAN BE EXPECTED?

- Repair and replacement of rock.
- Removal of sediment.
- Removal of rock.

NOTES

- Rock barriers placed around inlets will allow water to drain.
- Use only wire mesh instead of materials such as chicken wire.
- Rock barriers are to be installed in "sump" conditions only. Rock barriers in front of inlets on a grade will divert runoff to downstream locations.
- Rock barriers in front of inlets provide little filtering and capture little sediment from runoff waters for large frequency storm events.

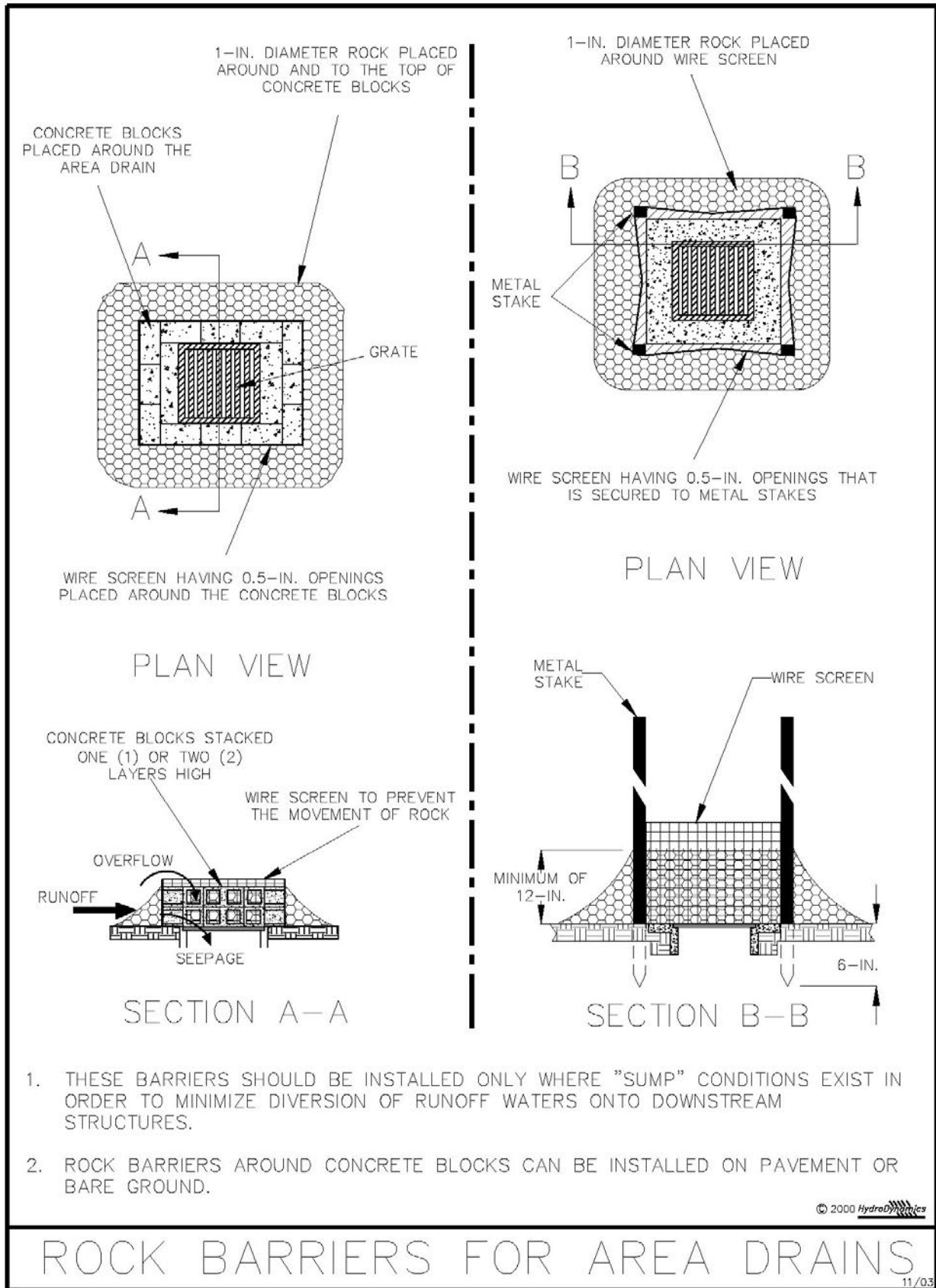

Figure V-13: Illustration of Rock Barriers around Area Drains

Permission is given by HydroDynamics Incorporated to copy and reproduce this detail

Frame & Filter Barrier for Area Drain (a.k.a. Drop, Catch Basin, or Ditch Bottom) Inlets

WHAT IS ITS PURPOSE?

Temporary barriers to cause waters to pond and drain so that sediment can settle out of runoff waters while construction activities occur.

WHERE AND HOW IS IT COMMONLY USED?

- Around median inlets.
- Around inlets to which runoff flows.

WHEN SHOULD IT BE INSTALLED?

- While construction activities are occurring.
- Only where “sump” conditions exist.

WHEN SHOULD IT NOT BE INSTALLED?

- After construction activities are completed.
- Where “sump” conditions do not exist.
- In locations that could lead to potential flooding such as encroachment on travel lanes of a roadway.

WHAT NEEDS TO BE INSPECTED?

- Has the unit been placed over the grate?
- Is there sufficient soil or gravel to seal the cover?
- Does accumulated sediment cover 2/3 of the filter barrier height?
- Does it appear that runoff is flowing under the fabric material?
- Do “sump” conditions exist?
- Is the fabric material torn?
- Is the frame still supporting the fabric material?
- Does runoff drain through the fabric material?

WHAT MAINTENANCE ACTIVITIES CAN BE EXPECTED?

- Repair and replacement of gravel in the pocket.
- Replacement of fabric material.
- Removal of sediment around the unit.

NOTES

- These barriers are to be installed in "sump" conditions only. If placed in front of inlets on a grade, runoff will be diverted to downstream locations and could cause flooding.
- It is critical that a good seal exist between the ground and fabric material using adequate amounts of soil or gravel.
- Multiple types of filter media are available for this system. The correct type of filter fabric should be chosen that considers both safety and environmental concerns.

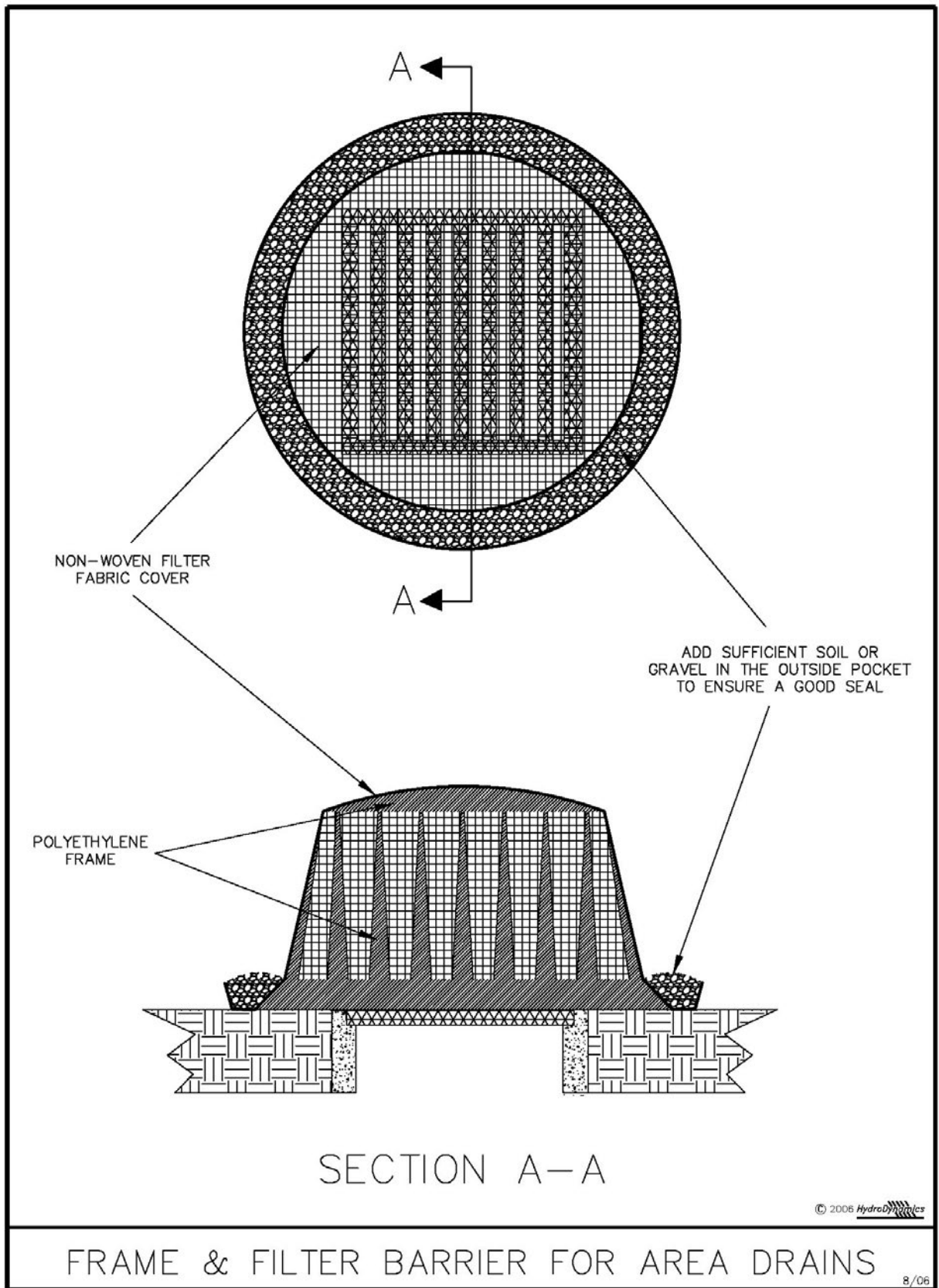

Figure V-14: Illustration of a Frame & Filter Barrier for Area Drains

Permission is given by HydroDynamics Incorporated to copy and reproduce this detail

Curb Inlet “Sump” Barrier

WHAT IS ITS PURPOSE?

Temporary barriers to cause waters to pond and drain so that sediment can settle out of runoff waters while construction activities occur.

WHERE AND HOW ARE THEY COMMONLY USED?

- In front of curb inlets.
- Reduce sediment entering a storm sewer system.

WHEN SHOULD IT BE INSTALLED?

- While construction activities are occurring.
- Only where “sump” conditions exist.

WHEN SHOULD IT NOT BE INSTALLED?

- After construction activities are completed.
- Where “sump” conditions do not exist.

WHAT NEEDS TO BE INSPECTED?

- Is at least 1.0-in. diameter rock used?
- Has wire mesh been used?
- Can water flow over the rock?
- Should the rock be replaced?
- Does water flow through the rock?
- Does the rock need "raking?"
- Will water be diverted downstream?
- Have vehicles destroyed the structure?

WHAT MAINTENANCE ACTIVITIES CAN BE EXPECTED?

- Repair and replacement of rock.
- Removal of sediment.
- Removal of rock.

NOTES

- Rock barriers are to be installed in “sump” conditions only.
- Wire mesh should be used instead of more open materials such as chicken wire.
- Rock barriers in front of inlets provide little filtering effect and capture little sediment from runoff waters.
- Warning signs should be used to alert drivers of the structures.
- Rock barriers in front of inlets may cause destruction of the pavement due to excess seepage of water or freezing conditions.
- If placed on a grade, the structure will divert runoff downstream and may cause flooding.

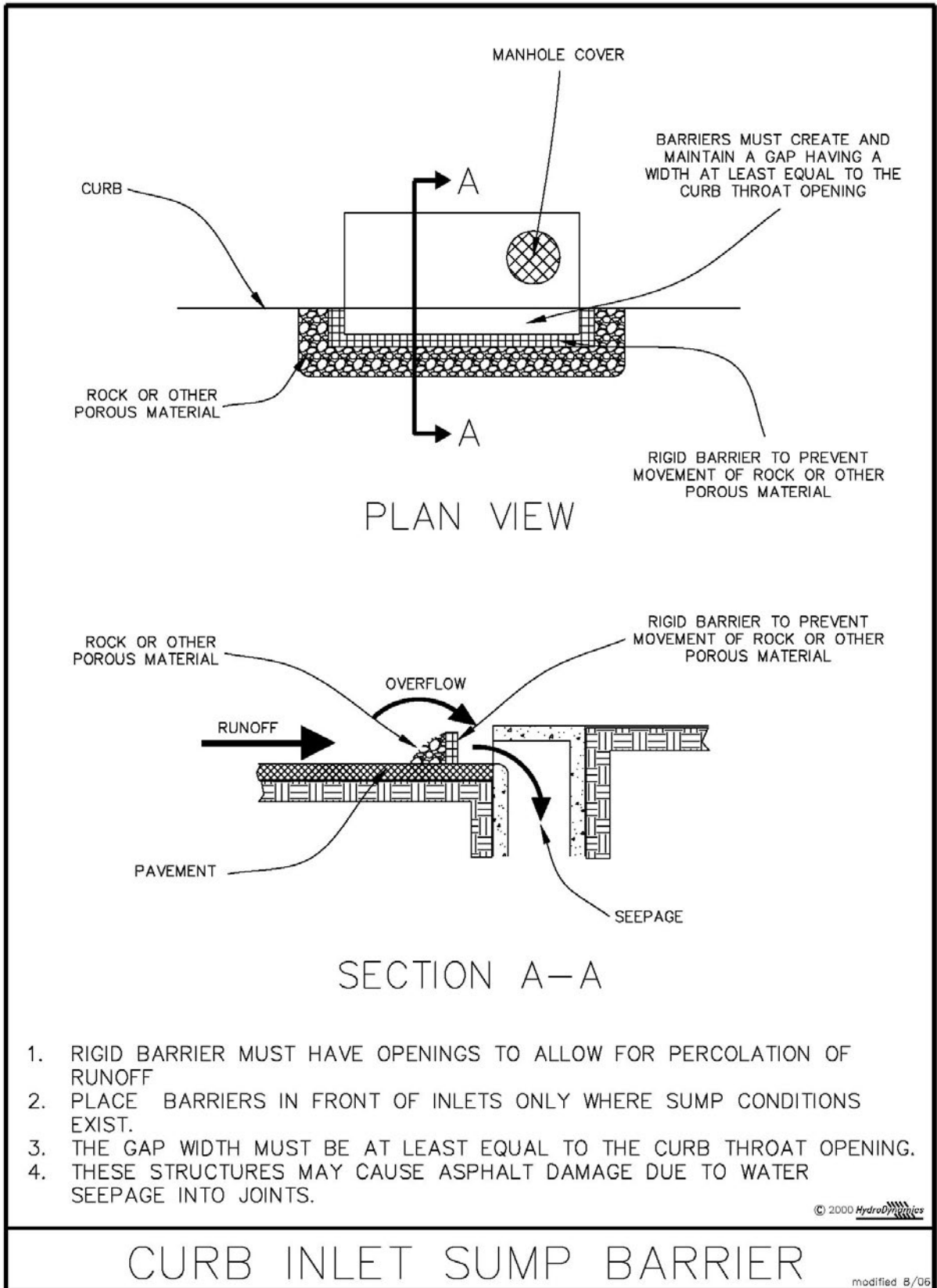

Figure V-15: Illustration of a Curb Inlet “Sump” Barrier

Permission is given by HydroDynamics Incorporated to copy and reproduce this detail

Curb Inlet Diversion Berm

WHAT IS ITS PURPOSE?

Temporary barriers to force runoff into a curb inlet when a downstream sediment containment system exists.

WHERE AND HOW IS IT COMMONLY USED?

- Immediately below an inlet opening.
- Used to force runoff into an inlet that drains into a sediment containment system.

WHEN SHOULD IT BE INSTALLED?

- While construction activities are occurring.
- At any curb inlet.

WHEN SHOULD IT NOT BE INSTALLED?

- After construction activities are completed.
- Where diverted runoff will not enter a sediment containment system.

WHAT NEEDS TO BE INSPECTED?

- Have the diversion bags been destroyed?
- Is water being diverted into the inlet?
- Should signage be installed?
- Should the bags be replaced?

WHAT MAINTENANCE ACTIVITIES CAN BE EXPECTED?

- Repair and replacement of bags.
- Removal of the diversion bags as full build out conditions develop.

NOTES

- Warning signs should be used to alert drivers of the structures.

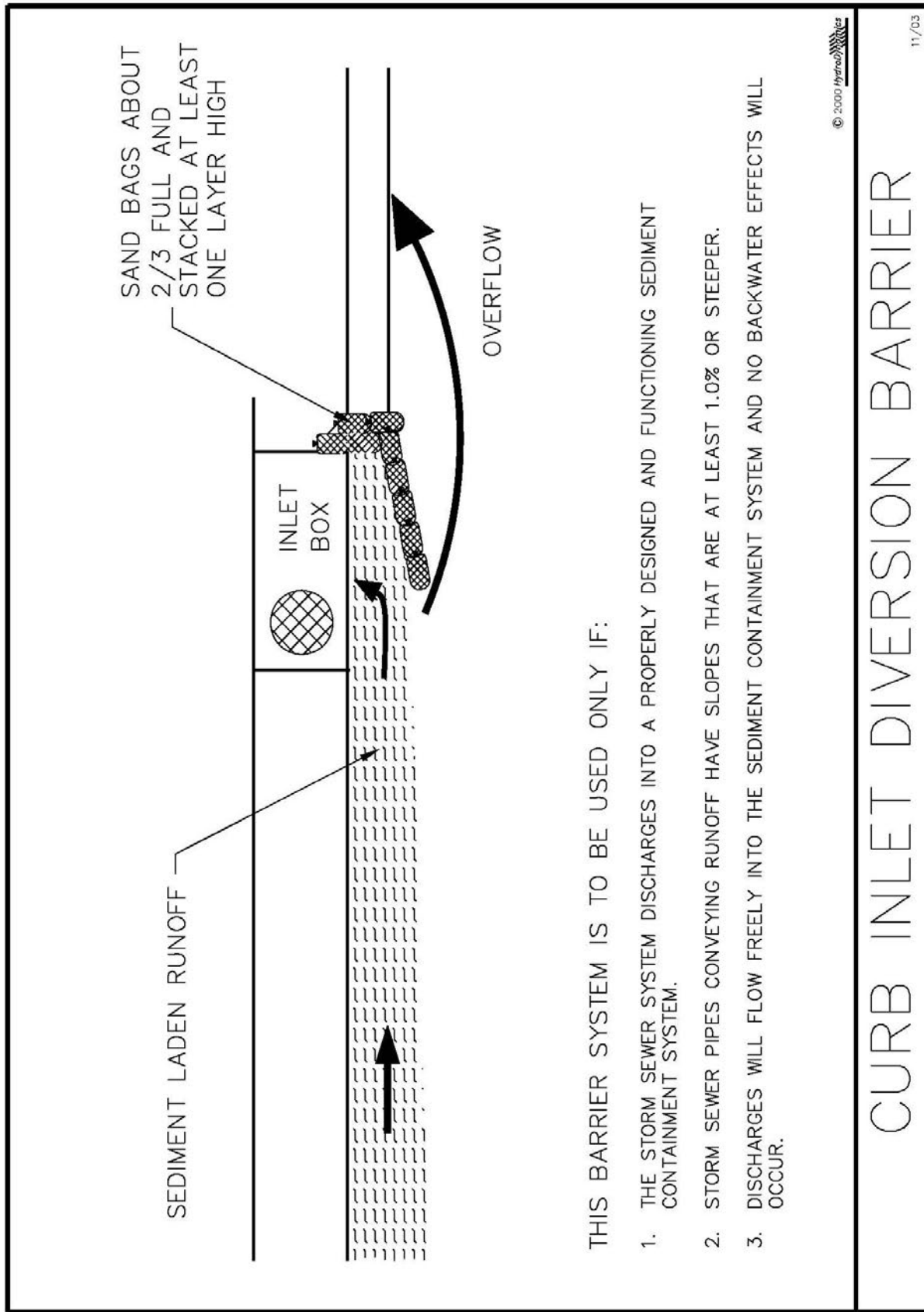

THIS BARRIER SYSTEM IS TO BE USED ONLY IF:

1. THE STORM SEWER SYSTEM DISCHARGES INTO A PROPERLY DESIGNED AND FUNCTIONING SEDIMENT CONTAINMENT SYSTEM.
2. STORM SEWER PIPES CONVEYING RUNOFF HAVE SLOPES THAT ARE AT LEAST 1.0% OR STEEPER.
3. DISCHARGES WILL FLOW FREELY INTO THE SEDIMENT CONTAINMENT SYSTEM AND NO BACKWATER EFFECTS WILL OCCUR.

© 2000 HydroDynamics

11/03

CURB INLET DIVERSION BARRIER

Figure V-16: Illustration of a Curb Inlet Diversion Berm

Curb and Gutter Sediment Containment System Detail

WHAT IS ITS PURPOSE?

Temporary barriers to cause waters to pond and drain so that sediment can settle out of runoff waters while construction activities occur.

WHERE AND HOW IS IT COMMONLY USED?

- In gutters and upstream of inlets.
- Reduce sediment entering a storm sewer system.

WHEN SHOULD IT BE INSTALLED?

- While construction activities are occurring.
- Where street grades exist.

WHEN SHOULD IT NOT BE INSTALLED?

- After construction activities are completed.
- Where “sump” conditions exist.

WHAT NEEDS TO BE INSPECTED?

- Are the bags about 2/3 full?
- Is collected sediment being removed?
- Is the spacing correct (see table)?
- Have vehicles destroyed the bags?

WHAT MAINTENANCE ACTIVITIES CAN BE EXPECTED?

- Repair and replacement of bags.
- Removal of sediment.
- Removal of bags.

NOTES

- Vehicles will destroy the bags.
- Warning signs should be used to alert drivers of the structures.
- Sediment must be removed after every runoff event.
- Water should not be allowed to remain behind the bags.

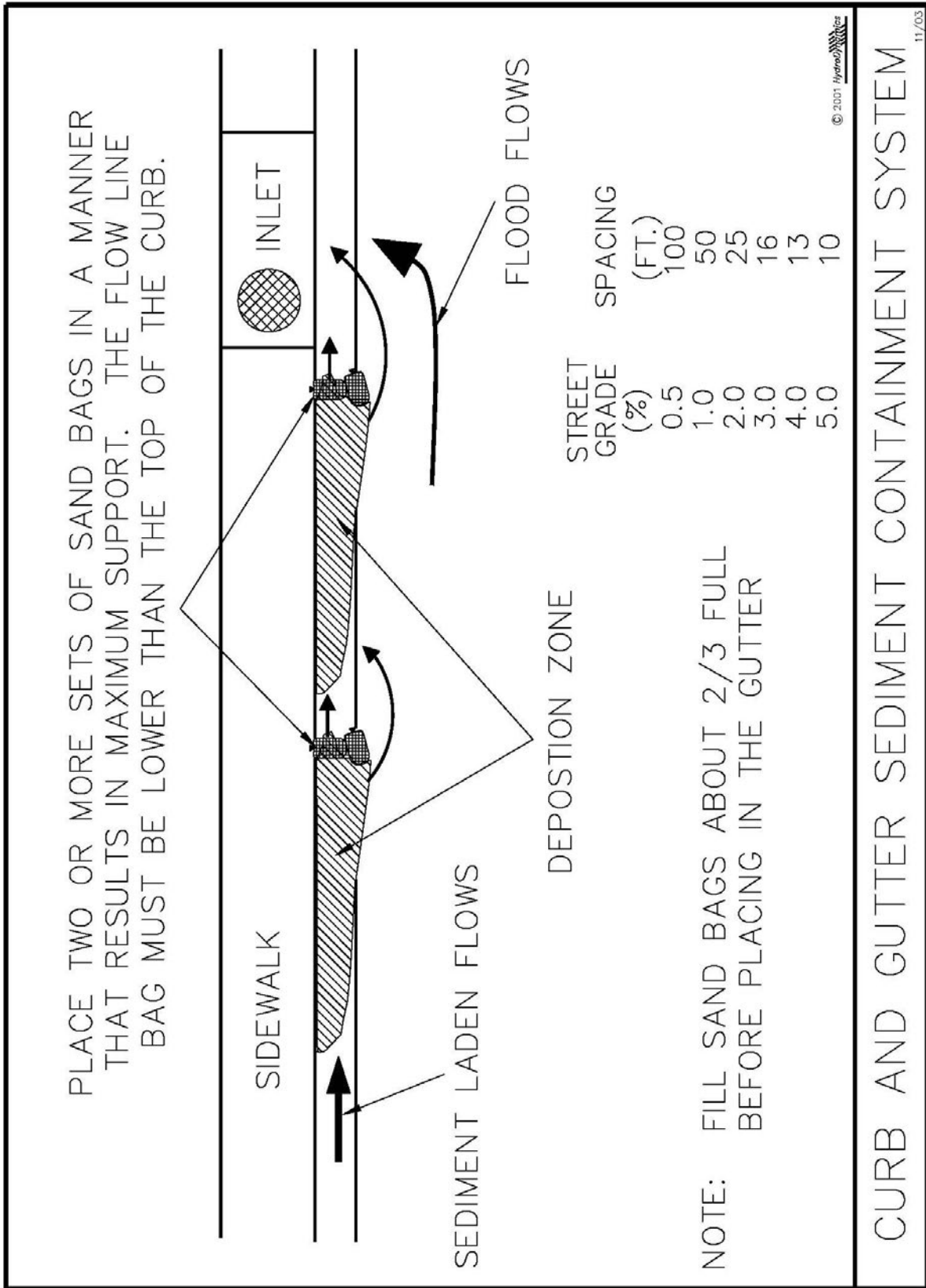

Figure V-19: Illustration of a Curb and Gutter Sediment Containment System

Permission is given by HydroDynamics Incorporated to copy and reproduce this detail

Curb Inlet Insert

WHAT IS ITS PURPOSE?

Temporary SCS inserted into an inlet to capture larger diameter sediments found in runoff waters.

WHERE AND HOW ARE THEY COMMONLY USED?

- Within curb inlets.
- Within a catch basin.

WHEN SHOULD IT BE INSTALLED?

- While construction activities are occurring.
- Within inlets that are on a grade or in a sump.

WHEN SHOULD IT NOT BE INSTALLED?

- At a location to serve as the only sediment containment system.

WHAT NEEDS TO BE INSPECTED?

- Is the fabric material torn?
- Is the containment bag over ½ full?
- Will water flow into the material?
- Does the fabric appear around the grate?

WHAT MAINTENANCE ACTIVITIES CAN BE EXPECTED?

- Repair and replacement of material.
- Removal of sediment.

NOTES

- Be sure to empty the units before winter conditions occur.
- Do not rely on these units to be the only sediment control devices on a construction site.

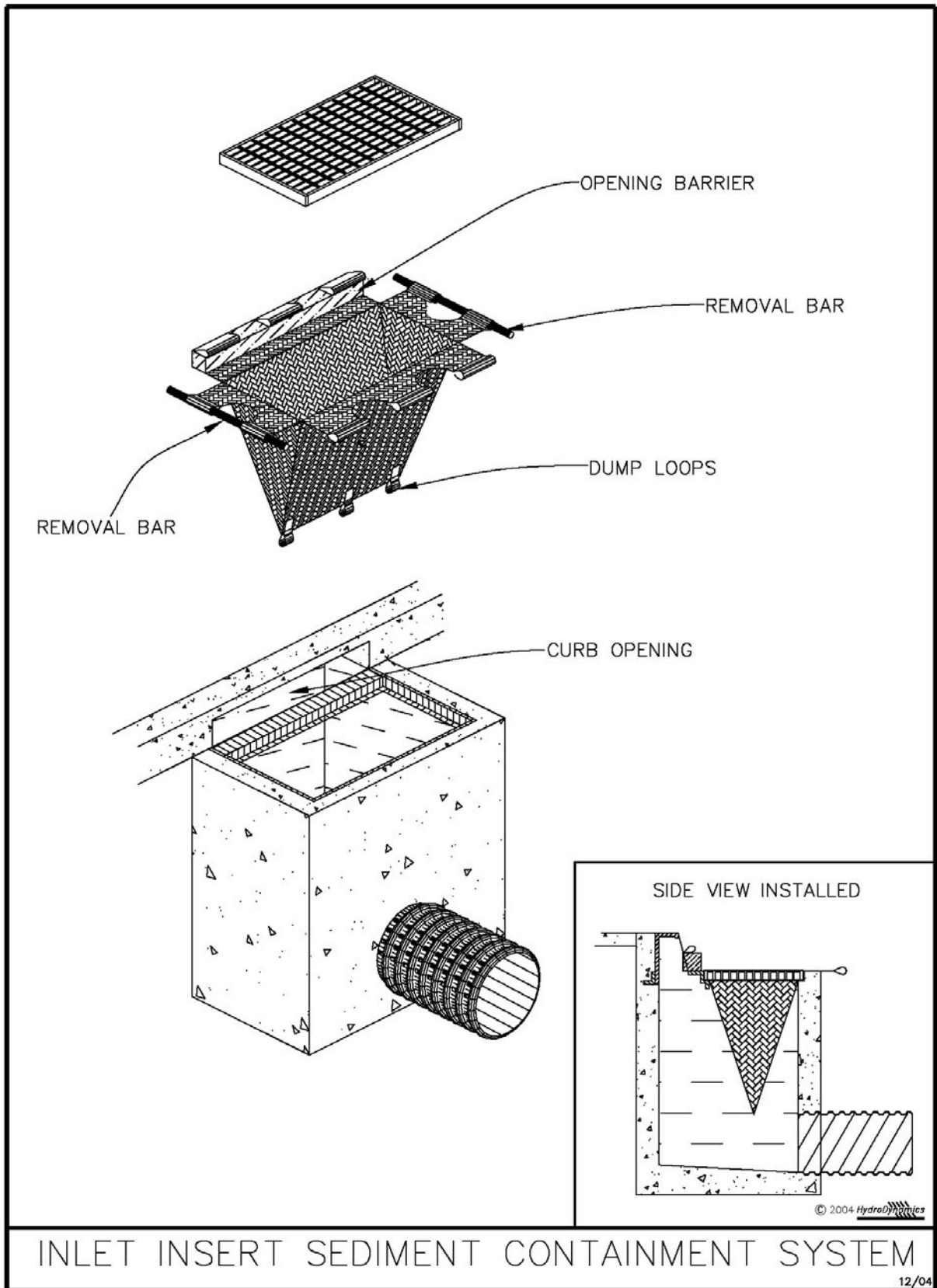

Figure V-18: Illustration of an Inlet Insert Sediment Containment System

Permission is given by HydroDynamics Incorporated to copy and reproduce this detail

Soil Tracking Prevention Device

WHAT IS ITS PURPOSE?

Temporary structures to assist with removal of soil material captured on vehicle tires entering and leaving a construction site.

WHERE AND HOW IS IT COMMONLY USED?

- Major entrances into construction sites.

WHEN SHOULD IT BE INSTALLED?

- Before construction activities begin.
- During construction activities.

WHEN SHOULD IT NOT BE INSTALLED?

- After construction activities are completed.

WHAT NEEDS TO BE INSPECTED?

- Are the correct rock diameters used?
- Is there a depression for runoff?
- Is rock being carried out into a street?
- Does rock need to be replaced?

WHAT MAINTENANCE ACTIVITIES CAN BE EXPECTED?

- Replacement of rock.
- Removal of sediment on adjacent streets.

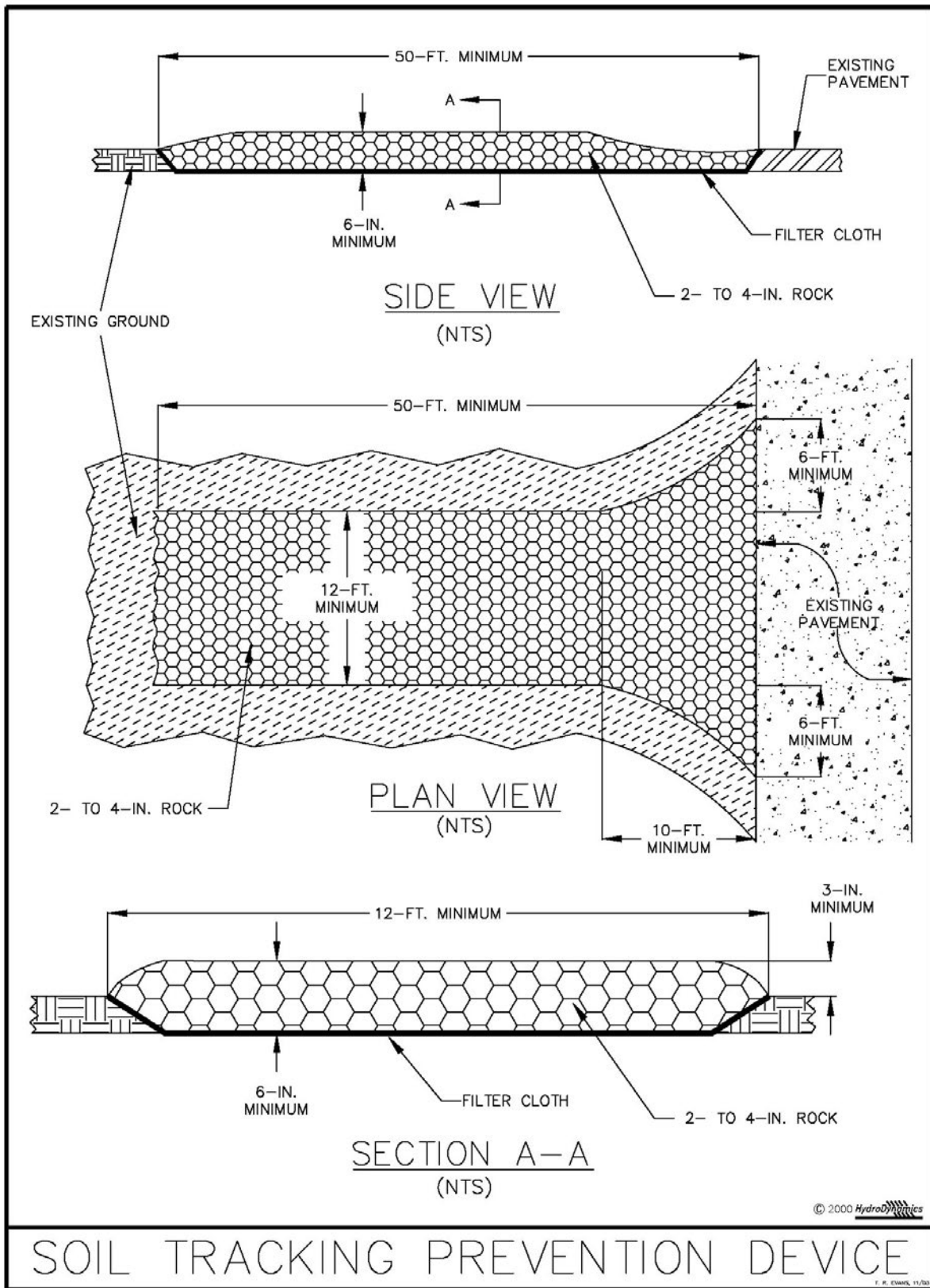

Figure V-19: Illustration of a Soil Tracking Prevention Device

Permission is given by HydroDynamics Incorporated to copy and reproduce this detail

Cellular Confinement System

WHAT IS ITS PURPOSE?

To protect hillsides or drainage channels against erosion due to flowing water or to be used as a temporary stream crossing.

WHERE AND HOW IS IT COMMONLY USED?

- In areas where concentrated flows occur and where greater erosion protection is needed that exceeds what a Rolled Erosion Control Product (RECP) provides.
- Provides a temporary stream crossing system that is able to withstand heavy loads and traffic.

WHEN SHOULD IT BE INSTALLED?

- While construction activities are occurring.
- After construction activities are finished.

WHEN SHOULD IT NOT BE INSTALLED?

Over impervious surfaces.

WHAT NEEDS TO BE INSPECTED?

- Does the system display any damage?
- Is the system held in place by staples or pins?
- Have all the cells been filled with rock, soils or cement?
- Has the system been installed as required by the manufacturer?
- Is a geotextile blanket used?
- If the cells are filled with soil, has seeding and mulching been completed?

WHAT MAINTENANCE ACTIVITIES CAN BE EXPECTED?

- Repair and replacement of cell material. ▪ Evaluation of material in cells.
- Slippage down a slope.

NOTES

- Possibly can be used as a temporary soil tracking prevention device.

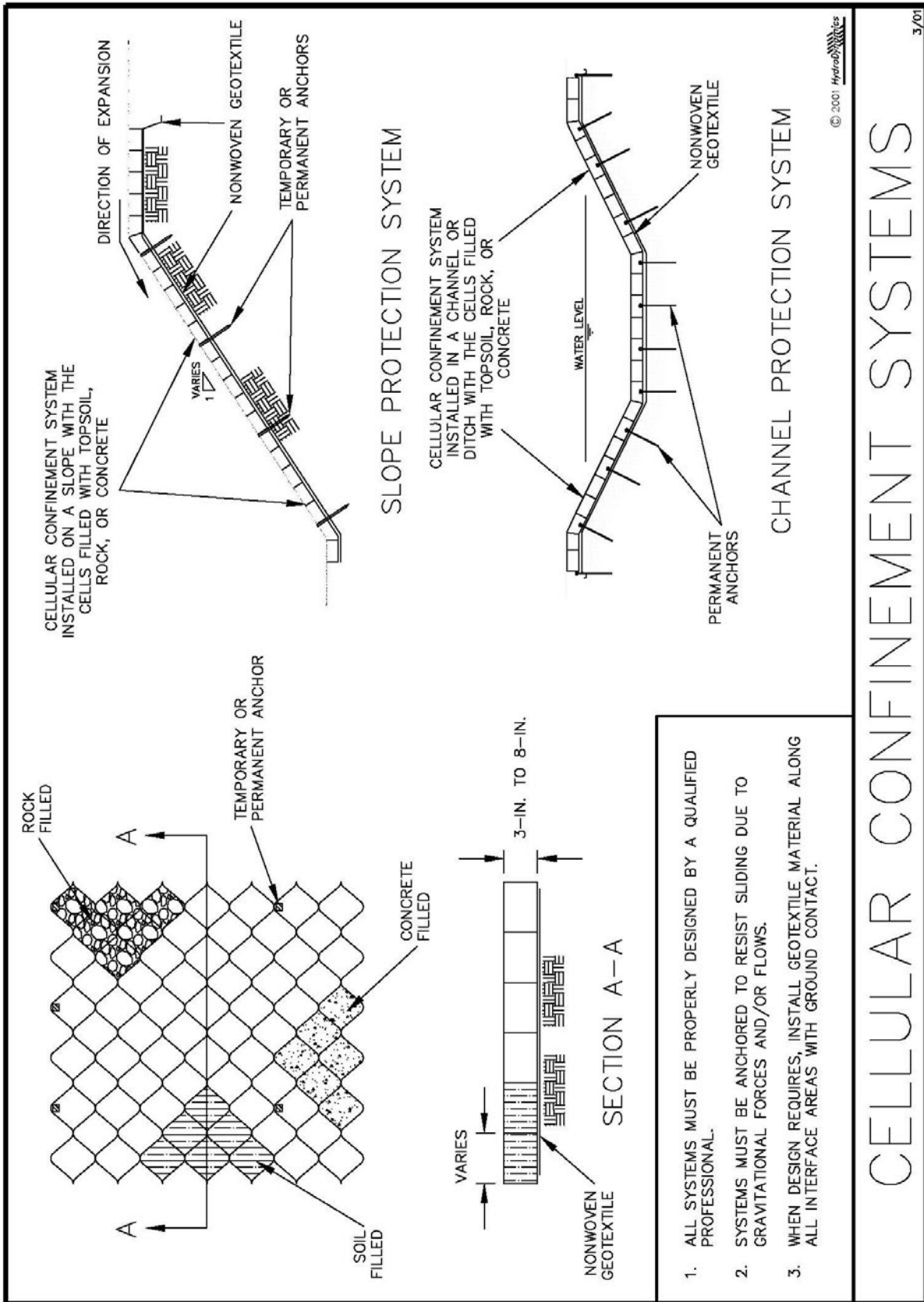

Figure V-20: Illustration of uses for Cellular Confinement Systems

Permission is given by HydroDynamics Incorporated to copy and reproduce this detail

Using BMPs When Building Box Culverts

Sections III, IV, and V provide illustrations of many different BMPs that can be utilized before, during, and after construction activities occur. Figure V-16 illustrates four different scenarios that might be considered in using different BMPs during the construction of box culverts.

Scenario No. 1: If a Designer is confident that offsite runoff waters will not discharge through the construction activity area, the only BMPs that may be necessary are properly installed silt fence barriers, slope drains, and erosion control of the embankments. Also, this scenario assumes that access to the construction site is through an existing (or under construction) roadway. Some important items for Designers to consider include:

- Concentrated off-site flows cannot discharge through the construction site.
- Access to the construction site is through an existing road.
- Topsoil storage, staging, and access to the site must be completed in a manner that ensures runoff from these areas discharge into a temporary containment system created by the silt fence barrier.
- A slope drain is installed to ensure road runoff is conveyed down the fill slope and away from the active construction site.
- Erosion protection of disturbed slopes must occur as soon as possible.

Scenario No. 2: Consideration of this scenario can occur when periodic offsite flows will not inundate the construction site and/or access cannot occur from an existing roadway. Some important items for Designers to consider include:

- Only periodic and small concentrated off-site flows will discharge through the construction site.
- All temporary earthen berms must be stabilized against erosion while construction activities occur.
- Topsoil storage and staging must be completed in a manner that ensures runoff from these areas discharge into the temporary containment system created by the earthen berm and rock outlet structure.
- Frequent maintenance activities can be expected to remove accumulated sediments and runoff waters.
- A silt fence barrier is required along the downstream side of an access road.
- A slope drain may be required to ensure road runoff is conveyed down the fill slope and away from the active construction site.
- Erosion protection of disturbed slopes must occur as soon as possible.

Scenario No. 3 and No. 4: These scenarios are perturbations of the first two scenarios when offsite flows need to be diverted and/or installation of box culverts occur through an existing or developing roadway. Along with items identified above, Designers also need to consider the following:

- If pumping is to occur, sufficient containment volume must exist for the anticipated inflow of offsite waters and removal by pumping.

- Erosion protection of any diversion channels and embankments must occur while construction activities happen.

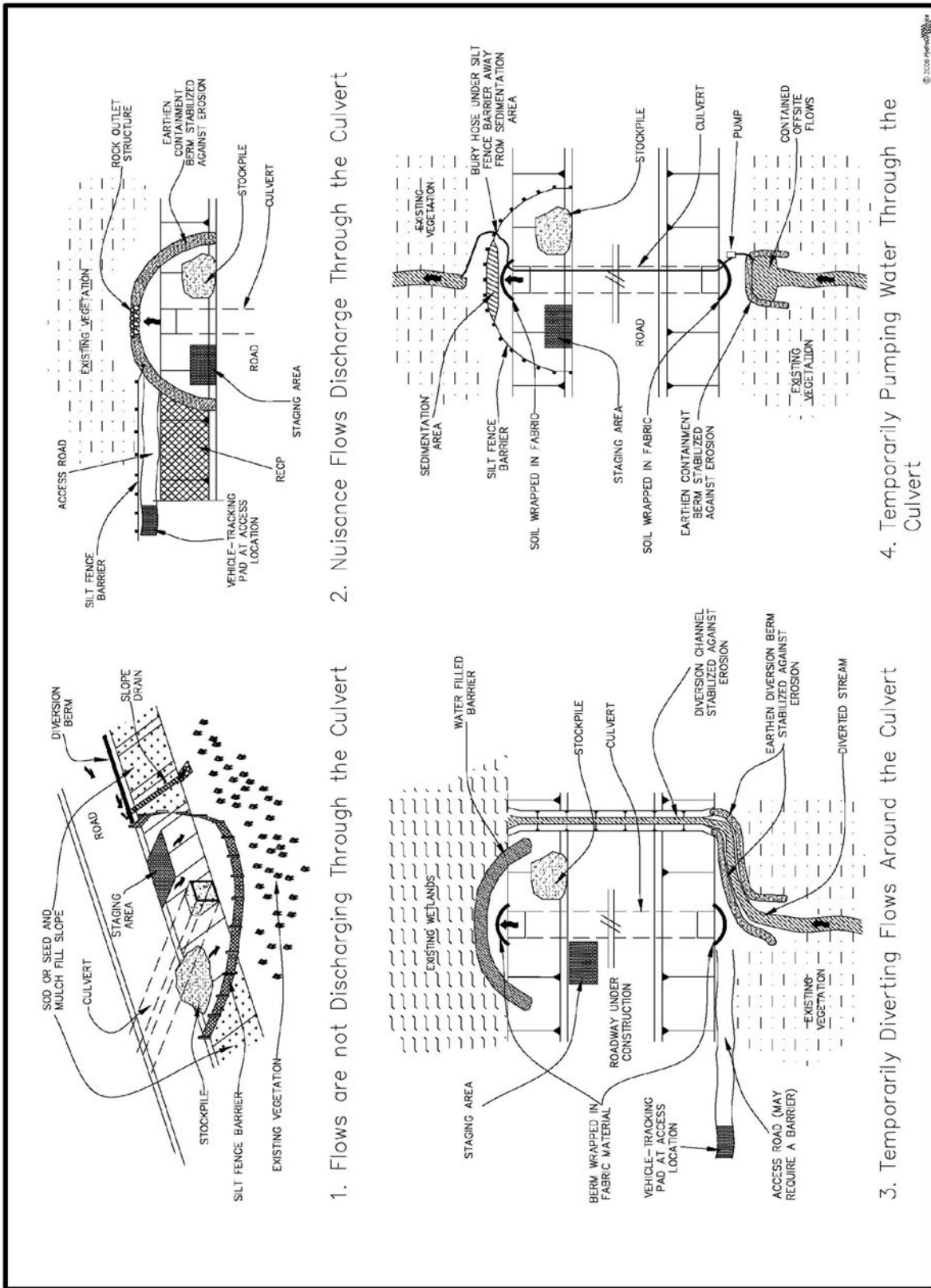

Figure V-21: Illustration of Using BMPs While Building Box Culverts

Permission is given by HydroDynamics Incorporated to copy and reproduce this detail

APPENDIX I.
COASTAL APPLICATIONS

INTRODUCTION

Overview of Coastal Settings

Construction sites in a coastal environment present unique challenges because of the direct link to sensitive water bodies and the limited available area to implement erosion and sediment control practices. Coastal settings are often subject to higher wind speeds, saline-laden air moisture, and wave action that require the selection of appropriate erosion control practices that can withstand these elements. Florida is partially surrounded by coastline and is often a target for tropical depressions, storms, and hurricanes. In addition, approximately 77% of Florida's population lives in coastal areas, necessitating continuous development of roads and infrastructure along Florida's coastline. Thus, there is a significant need for erosion and sediment control practices which can be adapted to coastal environments.

Purpose and Overview

This Appendix presents technologies available to designers, hydrologists, and construction personnel for mitigating erosion and sedimentation in coastal areas of Florida. The technologies are divided into two groups, Erosion Control Technologies and Sediment Containment Technologies. Temporary and permanent control technologies are presented for each group. The information provided for each technology includes:

- A description of the technology.
- The general purpose(s) of the technology.
- Considerations for implementation of the technology in coastal areas.
- When the technology should be installed.
- Where and when the technology should not be installed.
- Inspection and maintenance needs.

Additional specifications and steps for implementation of many of the technologies are provided in Sections I through V of this manual.

Design Considerations for Coastal Settings

Coastal environments present a number of challenges to infrastructure design, construction practices, and implementation of erosion and sediment control which are unlike challenges found in inland environments. These challenges often necessitate longer design processes, careful consideration and research of expected environmental conditions, and using designers and construction contractors who are experienced in coastal environments. Some of the elements to consider when designing infrastructure and developing erosion control plans are:

- Materials must be resistant to salt spray and contact with saline water.
- Coastal areas often have a high water table; excavation activities are therefore restricted. As a result, sediment containment ponds are often unpractical.
- Soil compaction and site preparation are difficult due to sandy, non-cohesive soils. In addition, sandy soils are easily transported in runoff.
- Coastal soils are typically alkaline and nutrient-poor, which provides a difficult medium for establishing soil-stabilizing vegetation. Selected vegetation must be salt-tolerant.
- Coastal areas are typically high-energy environments due to exposure to wind and waves; selected erosion control practices therefore must be resistant to these elements.

- Frequent maintenance of erosion and sediment control practices may be needed due to high exposure and damage potential.
- Tidal fluctuations can limit the area available for construction and for erosion and sediment control.
- Coastal watersheds can be large and difficult to delineate due to small changes in elevation, and it can be difficult to accurately estimate design storm runoff and to design proper erosion control features.
- Coastal geology in southern Florida is typically dominated by limestone rock (a.k.a. limerock). Limerock can be exposed to air and water during site excavation and roadbed construction. During storm events, the limerock can be easily eroded, resulting in milky-colored stormwater filled with fine sediment that is difficult to flocculate.
- Coastal environments in Florida are widely varied. Environments such as estuaries, inlets, open shoreline, reef-protected shoreline, and lagoons have different conditions, including wave energy, wind exposure, tidal fluctuations, and cross-currents. These conditions must be thoroughly evaluated for each site prior to the design of erosion control features.

This Appendix provides guidance to the designer or construction contractor when selecting appropriate erosion and sediment control technologies for coastal areas. However, much of the material presented is also applicable to interior lands. General design and technology sizing information is provided in Sections I through V of this manual. Where possible, detailed design information related to coastal environments is presented in the technology summaries that follow.

EROSION CONTROL TECHNOLOGIES

Temporary Controls

Compost/Wood Mulching

-- *A mixture of compost, wood mulching, bark, or other vegetative material applied to an area. Materials include: shredded wood (wood chips, wood bark, wood cellulose fiber, and wood excelsior) and other organic material (vegetative trimmings such as grass, shredded shrubs, and trees).* --

What is its Purpose?

- To reduce soil erosion through temporary soil stabilization.
- To protect exposed soil from wind and raindrop impact.
- To decrease velocity of runoff over exposed soil areas, thereby increasing infiltration.
- To provide an appropriate medium for the growth of seeds for further stabilization.

Where and How is it Commonly Used in Coastal Areas?

- Can be applied to exposed soil surfaces, often up to the soil/water interface.
- May be applied by hand or by mechanical methods.
- Best performance is on slopes 1:5 (*V:H*) or flatter.
- Caution should be used when applying mulch or compost at the soil/water interface because of the potential for sedimentation of the water body.
- If on-site vegetation is used, ensure that invasive species such as melaleuca and Brazilian pepper are removed from the site prior to grinding or shredding of existing vegetation.
- If shredded wood is used, evenly distribute material across the soil surface to a depth of 2 to 3 inches. Desired application rates are as follows:
 - Wood chips or bark: 4 to 6 tons per acre
 - Wood cellulose fiber: 0.5 to 1.0 tons per acre

- Wood excelsior: 2 tons per acre
- If vegetative trimmings are used, evenly distribute material across the soil surface to a depth of not more than 2 inches. Application rates vary widely based on source of material.
- Vegetative trimmings, wood cellulose fiber, and wood excelsior are the best choices if the soil surface is to be seeded, since seed germination is often difficult under a thick, heavy wood chip or bark cover.
- The application of a soil binder is required in most coastal areas to maintain placement of mulch. Follow guidelines for soil binder selection and application rates under “Soil Binders” in this Appendix.

When Should it be Installed?

- While construction activities are occurring.
- After construction activities are completed.

Where and When Should it not be Installed?

- Areas with heavy wave action or concentrated flows.
- Slopes greater than 1:3 (*V:H*).
- Areas with high tidal fluctuations.
- Avoid placement of mulch on pavement, sidewalks, existing or expected drainage channels, and on existing vegetation.

What Needs to be Inspected?

- All areas of application on a weekly basis, particularly after a heavy storm or wave action.

What Maintenance Activities can be Expected?

- Bare areas must be re-covered with mulch/compost immediately, or if removal is somewhat uniform, reapply when more than 20% of ground is exposed in application area.

Notes

- Wood fiber mulches are typically short-lived.
- Undesirable weeds can be introduced in the mulch.
- Possible introduction of organic (tannic) acids and dissolved organic carbon from decaying plant material to nearby coastal water bodies can occur.

Design Example

Photos of Application



Wood and bark mulch (Source: KCSWCD, 2006
2007)



Wood excelsior fiber close-up (Source: Wholesale Supplies,

Design Example

See design example under “Hydraulic Mulch” in this Appendix.

Hydraulic Mulch

-- *A mixture of shredded wood fiber or a bonded fiber matrix and a soil binder such as a stabilizing emulsion, tackifier, or lineal non-toxic polymer, applied with specialized hydro-mulching equipment. Common soil binders included in hydraulic mulch are acrylic polymer, guar gum, and psyllium (plantago).* --

What is its Purpose?

- To reduce soil erosion through temporary soil stabilization.
- To protect exposed soil from wind and raindrop impact.
- To decrease velocity of runoff over exposed soil areas and increase infiltration.
- To provide an appropriate medium for the growth of seeds for further stabilization.

Where and How is it Commonly Used in Coastal Areas?

- Most applicable for temporary stabilization of surfaces that are either expected to be re-disturbed at a later time or are expected to be treated with permanent stabilization measures.
- Typically applied by hydraulic methods.
- For most effective soil stabilization and coverage, exposed soil surface should be loose (un-compacted) at time of application. Soil areas can be roughened by rolling the surface with a crimping or punching-type roller or by track walking to increase the soil surface area available for binding to the hydraulic mulch.
- Exposed soil areas should be covered completely.
- Choose a tackifier/binder that does not introduce contaminants into the adjacent water body.

- Follow guidelines for selection and application rates of binders under “Soil Binders” in this Appendix.
- Typical hydraulic mulch application rates are as follows:
 - Wood fiber mulch: 2,000 – 4,000 lbs/acre
 - Wood fiber with acrylic polymer or other binder: 2,000 – 4,000 lbs/acre wood fiber mulch with 5-10% by weight of binder
 - Bonded fiber matrix with acrylic polymer: 3,000 – 4,000 lbs/acre
- See individual manufacturer’s recommendations for mixture specifications and desirable moisture content of hydraulic mulches.
- Binders *may* require up to a 24-hour cure time to be effective, so weather patterns should be closely monitored during and immediately after application. However, required curing time can vary widely and can be binder-specific. For example, lineal non-toxic binding polymers do not require a cure time. Always check manufacturer’s recommendations prior to use of a soil binder in hydraulic mulch.

When Should it be Installed?

- While construction activities are occurring.
- After construction activities are completed.

Where and When Should it not be Installed?

- Not suitable for areas with high wave energy (average wave height > 1.2 feet) or concentrated flows.
- Area of application is limited in areas with high tidal fluctuations.

What needs to be Inspected?

- Inspect areas of application after a heavy storm or heavy wave action
- Look for bare areas where mulch/compost was removed.

What Maintenance Activities can be Expected?

- Bare areas must be re-covered with mulch/compost immediately, or if removal is somewhat uniform, reapply when more than 20% of ground is exposed in application area.

Notes

- Avoid spraying hydraulic mulch on adjacent water body or existing vegetation.
- Some materials are susceptible to removal or disturbance by wind in exposed areas.
- Wood fiber hydraulic mulches are typically short-lived.
- Undesirable weeds can be introduced in mulch.

Design Example

Photos of Application



Hydraulic mulch sprayer (Source: Price and Company, 2006) Dyed hydraulic mulch (Source: Terra-Mulch, 2006)

Design Example

A designer on a 25-acre coastal construction project selects hydraulic mulch for temporary soil stabilization as construction activities are phased across the site. She selects fiber hydraulic mulch with a 10% (by weight) polyacrylamide binder content. She identifies the maximum expected high tide elevation during the construction period prior to establishment of permanent erosion controls and marks this point as the limit of the area to be mulched. The volume of hydraulic mulch and binder needed are calculated as follows:

$$\text{Weight of mulch needed} = \text{Exposed area} \times \text{Mulch application rate}$$

$$\text{Weight of mulch needed} = 25 \text{ acres} \times 1.5 \text{ tons/acre}$$

$$\text{Weight of mulch needed in mix} = 37.5 \text{ tons}$$

Soil Binders

-- Similar to hydraulic mulch, but material includes only a stabilizing emulsion, tackifier, or polymer. General categories of soil binders are plant-based (short- and long-lived), polymeric emulsion blends, cementations binders, lineal non-toxic polymer of high molecular weight, and dry polymeric binders. Typical soil binders are guar gum, psyllium (plantago), starch, pitch/rosen mixture, acrylic copolymer, methacrylate, acrylate, sodium acrylate, polyacrylamide, hydro-colloid polymer, and gypsum. --

What is its Purpose?

- To prevent soil erosion through temporary soil stabilization.

Where and How is it Commonly Used in Coastal Areas?

- Can be used for temporary stabilization of sandy soils in areas with high erosive potential or potential for wind erosion.
- Soil binders tend to work well in areas with high relative humidity, which is typical of coastal areas.
- Typically applied by hydraulic equipment. In some cases, binders may be applied as dry powder with a hand or mechanical spreader, but only when recommended by the manufacturer.
- **Table 1** shows properties of commonly-used soil binders.
- For most effective soil stabilization and coverage, exposed soil surface should be loose (un-compacted) at time of application.
- Exposed soil surface may need to be pre-wetted prior to application. Check binder manufacturer's recommendations.
- Area may need to be crowned or sloped to avoid ponding of binder.
- Avoid spraying binder on adjacent water body, existing vegetation, sidewalks, and roadways.
- Exposed soil areas should be covered completely.
- The selected binder should not introduce contaminants to the adjacent water body and should be non-toxic to plant and animal life.
- Longer cure times (>24 hours) may be needed with some types of binders due to high humidity and salt-laden moisture in coastal areas. Check binder manufacturer's recommendations. Lineal non-toxic polymers, which can be used for binding, tackification, and water clarification, do not require a cure time.
- More than one treatment layer may be necessary.
- Some materials are susceptible to removal or disturbance by wind in exposed areas.
- Some binders require at least a 24-hour cure time to become effective, so weather patterns should be closely monitored during and immediately after application. However, required curing time can vary widely and can be binder-specific. Always check manufacturer's recommendations prior to application of a soil binder.
- See Appendix III for further discussion of polymer flocculants and binders.

When Should it be Installed?

- During construction activities, can be used in areas that need short-term stabilization and will soon be re-worked or re-graded.

Where and When Should it not be Installed?

Not suitable for areas with high energy environment (average wave height > 1.2 feet), concentrated flows, or high tidal fluctuations.

- Not suitable long-term unless combined with another treatment measure.

- Not suitable for areas where contaminants from soil binder can be introduced to nearby coastal water bodies.
- Should not be used in areas expected to have heavy pedestrian or vehicular traffic.

What needs to be Inspected?

- Inspect areas of application after a heavy storm or heavy wave action.
- Examine area for bare areas where binder has undergone spot failure or has been removed.
- A sampling and analysis plan and associated inspection plan should be implemented by the designer to ensure binder is not leaching to adjacent water body at the soil/water interface.

What Maintenance Activities can be Expected?

- Bare areas must be re-covered with binder immediately, or if removal is somewhat uniform, reapply when more than 20% of ground is exposed in application area.

Notes

- Documentation of toxicity testing may be required if a polymer is selected as a soil binder, especially in biologically-sensitive coastal areas. See Appendix III for further information.

Table 1. Properties of Soil Binders for Erosion Control (Source: CalTrans, 2004).

Evaluation criteria	Binder type					
	Plant material based (short lived)	Plant material based (long lived)	Polymeric emulsion blends	Cementations binders	Lineal non-toxic polymer	Dry polymeric binders
Relative cost	low	low	low	low	low	low
Resistance to leaching	high	high	low to moderate	moderate	low to moderate	low to moderate
Resistance to abrasion	moderate	low	moderate to high	moderate to high	moderate to high	moderate to high
Longevity	short to medium	medium	medium to long	medium	medium to long	medium to long
Minimum curing time before rain	9 to 18 hours	19 to 24 hours	0 to 24 hours	4 to 8 hours	no cure time	no cure time
Compatibility with existing vegetation	good	poor	poor	poor	good	good
Labor intensive	no	no	no	no	no	no
Specialized application equipment	water truck or hydraulic mulcher	water truck or hydraulic mulcher	water truck or hydraulic mulcher	water truck or hydraulic mulcher	water truck or hydraulic mulcher	hand or mechanical spreader
Liquid/powder	powder	liquid	liquid/powder	powder	liquid/powder	powder
Surface crusting	yes, but dissolves on rewetting	yes	yes, but dissolves on rewetting	yes	yes, but dissolves on rewetting	yes, but dissolves on rewetting
Clean up	water	water	water	water	water	water

Design Examples

Photos of Application



Soil tackifier applied by sprayer truck (Source: SoilTac, 2006)



Soil binder and seed mixture applied near coastal bay (Source: SoilTac, 2006)

Design Example

Mock Site Plan

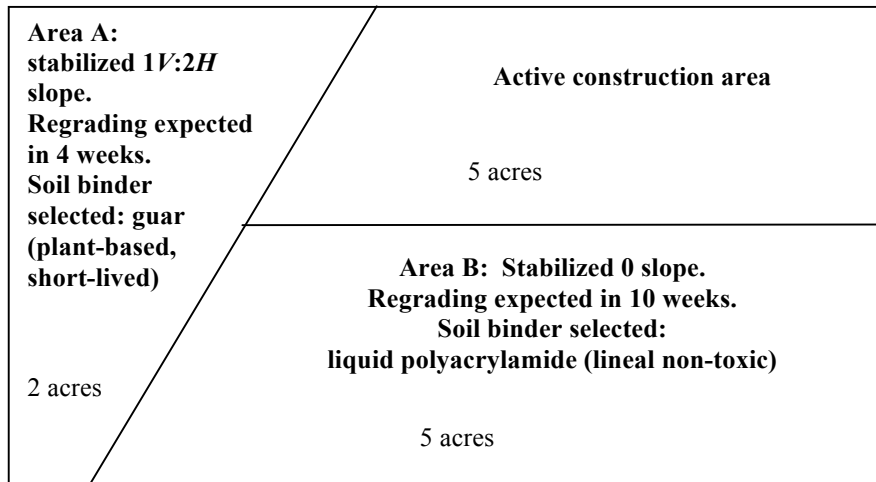

A designer on a 12-acre coastal construction project selects two soil binders for temporary soil stabilization as construction activities are phased across the site. The amount of binder needed is calculated as follows:

Area A: Guar soil binder

Weight of binder needed = Exposed area x manufacturer-recommended binder application rate

Weight of binder needed = 2 acres x 60 lbs/acre (example for soil and slope conditions)

Weight of binder needed = 120 lbs

Area B: Polyacrylamide soil binder

Weight of binder needed = Exposed area x manufacturer-recommended binder application rate

Weight of binder needed = 5 acres x 5 lbs/acre (example for soil and slope conditions)

Weight of binder needed = 25 lbs

Temporary Hydroseeding

-- *Hydroseeding is the application of a mixture of water, wood fiber, seed, fertilizer, and a soil stabilizer to temporarily protect exposed areas of soil from erosion due to wind, rain, and runoff. Common seed types used in Florida are bahia, bermuda, bahia/bermuda mix, and annual type ryegrass. Additional seed types that are being tested by the Natural Resource Conservation Service, and may soon become available, for use in temporary or permanent stabilization of soil in construction areas are: eastern gamagrass, lopsided indiagrass, chalky bluestem, hairawn muhly, switchgrass, and wiregrass (NRCS, 2006).* --

What is its Purpose?

- To reduce soil erosion through temporary soil stabilization.
- To provide an appropriate medium for the growth of seeds for further stabilization.

Where and How is it Commonly Used in Coastal Areas?

- Seeds are applied using a hydroseeder.
- Seeds that are tolerant to salt water and salt-laden moisture should be selected. In addition, chosen plants should be able to grow quickly in mineral soils with few nutrients.
- Refer to guidelines under “Establishing Permanent, Salt-Tolerant Vegetation” in this Appendix for selecting appropriate seed types for hydroseeding in coastal areas. The designer should always consult with a local agronomist on selection of appropriate seed types.
- For most effective coverage, exposed soil surface should be loose (un-compacted) at time of application. Soil areas can be roughened by rolling the surface with a crimping or punching-type roller or by track walking to increase the soil surface area available for seeding.
- For best results, cover hydroseed layer with a mulch layer to keep applied seeds in place, retain soil moisture, and control soil temperature during seed establishment. Follow guidelines for selection and application rates for mulch under “Hydraulic Mulch” in this Appendix.
- The application of a soil binder may be necessary to further stabilize hydraulic mulch and seed to allow for germination and continued growth of vegetation. Follow guidelines for binder selection and application rates under “Soil Binders” in this Appendix.
- Due to the lack of nutrients in most coastal soils, hydroseeding may need to be used in conjunction with another measure such as the application of mulch and fertilizer in order for the seeds to germinate and become effective in reducing erosion.
- Fertilizers should be included only when soil tests indicate a lack of adequate nutrients to establish and sustain the selected vegetation.
- If fertilizers and/or soil stabilizers are used, additional sediment control measures must be implemented to retain materials on-site and limit transport to and contamination of adjacent water bodies.

When Should it be Installed?

- While construction activities are occurring.
- After construction activities are completed.

Where and When Should it not be Installed?

- Avoid application of hydroseed on existing vegetation, water bodies, sidewalks, and roadways.
- Should not be used in areas where re-disturbance is expected within 4-6 weeks.

What needs to be Inspected?

- Inspect area before a precipitation event to make sure it is properly protected.
- Inspect area after a precipitation event and/or heavy wind for any removal of vegetation, mulch, or other stabilization material.

What Maintenance Activities can be Expected?

- Repair coverage and re-apply hydroseed material as needed to maintain maximum protection against erosion.
- If plant seeds fail to germinate, or established plants die, area must be re-seeded. Consider consulting with an agronomist for selecting other seed types if widespread failure of plants occurs.

Notes

- The temperate climate of most coastal areas in Florida allows for an extended growing season in which seeding can be applied.
- Depending on the type of seed selected, the temporary vegetation applied through temporary hydroseeding may have to be removed prior to the application of permanent seeding.

Design Examples

Photos of Application



Hand application of hydroseed on construction sites (Source: RMB Craftscapes Ltd, 2006)

Permanent Controls

Polymer-Enhanced Armoring

-- *Armoring is the permanent stabilization of a coastline or streambank that is eroding or susceptible to erosion, using natural or organic materials often in conjunction with a soil stabilizer such as a polymer. Armoring includes nourishing beaches with sand or shells, constructing marshlands, planting submerged aquatic vegetation, planting grass/sod or other salt-tolerant vegetation, and installing natural fiber logs. Possible combinations include:*

- *Rip-rap, jute-mat with polyacrylimide, and sod or grass seed.*
- *Low-profile rock or rubble with marsh vegetation.*
- *Oyster reefs with stone containment groins.*
- *Geo-grid material with implanted marsh vegetation.*
- *Beach replenishment with living breakwater (low profile breakwater made with marine limestone rock and oysters). –*
-

What is its Purpose?

- To reduce soil erosion through permanent soil stabilization in low to medium energy environments (average wave height < 1.2 feet).
- In some cases, to slow the velocity of runoff to a water body.

Where and How is it Commonly Used in Coastal Areas?

- Armoring can be used to dampen wave impact and to protect shorelines from erosion.
- Armoring can be used when construction is conducted in coastal areas to protect shorelines from greater runoff volumes.
- Some armoring techniques can serve as a filtration system for removing sediment in runoff prior to transfer to the adjacent water body.
- Armoring can preserve or provide for more habitat for benthic, estuarine, shallow water, and inter-tidal organisms.
- The area protected should extend well beyond and below the expected high and low tidal elevations to provide adequate erosion protection and undercutting of the medium.

When Should it be Installed?

- While construction activities are occurring.
- After construction activities are completed.

Where and When Should it not be Installed?

- High energy environments (average wave height > 1.2 feet) with heavy wave action and wind.
- Areas where access is limited and maintenance is costly.

What needs to be Inspected?

- Inspect area before a precipitation event to make sure it is properly protected.
- Inspect area after a precipitation event, heavy wind, and/or high water event for any removal of media.

What Maintenance Activities can be Expected?

- Repair coverage and re-apply media as needed to maintain maximum protection against erosion.
- If failure of media occurs routinely, consider another type or size of protective media.

Design Examples

Photos of Application



Armoring with oyster habitat and constructed wetlands
(Source: NOAA, 2006)



Armoring on beach with jute netting and salt-tolerant
vegetation (Source: Foundation Technologies, 2006)

Case Study: Polymer-Enhanced Armoring

Damage to U.S. Highway 98 from Hurricane Dennis, Florida Panhandle, 2005

Information provided by Josh Boan (FDOT), Michael Shepard (FDOT), and Steve Iwinski (Applied Polymer Systems, Inc.), 2006.

On July 10, 2005, Hurricane Dennis raged through the Florida Panhandle near Apalachicola and St. George’s Island. It made landfall at 3 pm as a Category 3 Hurricane with a maximum sustained wind near 140 mph. U.S. Highway 98, a major tourism and transportation corridor that snakes along the Panhandle’s coastline, was a prime target for hurricane damage.



Path of Hurricane Dennis, July 2005. Area of greatest damage on US Highway 98 was in the east-central portion of the Florida Panhandle.

Damage was severe on approximately 14 miles of U.S. Highway 98, ranging from erosion of the shoulder to buckling and subsidence of the entire roadway.



Front slope and shoulder damage on highway, July 12, 2005



Full roadway damage on a portion of highway, July 12, 2005

Immediately, the Florida Department of Transportation (FDOT) took action to re-construct and open traffic on the stretch of damaged highway and awarded a construction contract to complete emergency repairs within 14 days. Travel lanes were reconstructed and traffic soon resumed; within a month, however, shoulder erosion was reoccurring, threatening to again encroach on travel lanes.



Evidence on sheet erosion and undercutting of sod, August 2005



Sheet and gully erosion along shoulder, August 2005

FDOT immediately sought to implement a short-term (1-2 years) solution to protect the roadway and minimize sheet erosion of shoulders until a more permanent plan could be developed. Due to the proximity of the highway to the ocean and high exposure to saline-laden moisture and wind, any vegetation used to stabilize the shoulders and front slopes would have to be able to resist harsh environments.

FDOT consulted with Applied Polymer Systems and developed a polymer-enhanced armoring countermeasure that was cost-effective and met design objectives. The design consisted of the following elements:

- Removal of existing turf and grading of shoulders and front slopes
- Compost – 2” depth
- Jute fiber erosion control blanket
- Polyacrylamide (PAM) powder (Silt Stop, QPL#M-0203) – applied at a rate of 50 lbs/acre
- Vegetation – bermuda grass sod
- Temporary silt fence installed at base of front slope or shoulder

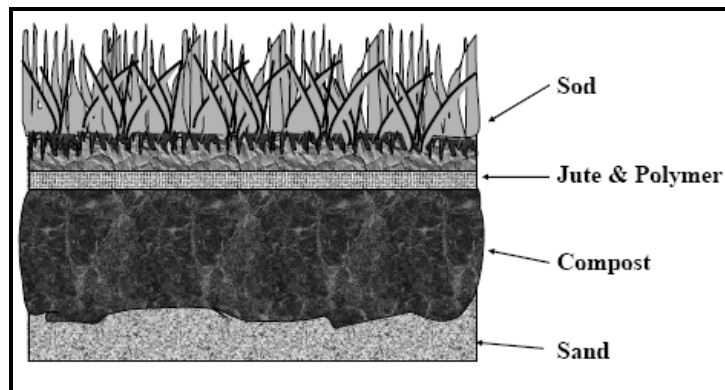

Cross-sectional schematic of armoring design layers used on U.S. Highway 98 (Applied Polymer Systems, 2006)



Placement of compost mulch layer



Placement of jute fiber erosion control blanket



Placement of bermuda grass sod over jute blanket



Final placement of sod

The jute erosion control blanket provided an initial attachment surface for the PAM powder. The soil-specific PAM reacted with metals and fine, clay-sized particles, binding the soil together and promoting flocculation of fines that were transported in stormwater runoff. The polymer/soil complex further bound to the jute mat and surrounding soil in the compost and sod layers, creating a highly erosion-resistant matrix that allowed the establishment of vegetation.

One year later (August 2006), the polymer-enhanced armoring technique is performing well, requiring little maintenance and successfully mitigating coastal erosion. Over time, the jute blanket is expected to biodegrade, and the sod vegetation will continue to establish roots in the underlying topsoil.



Armoring in place, one year later



Roadway and shoulder successfully protected

Establishing Permanent, Salt-Tolerant Vegetation

-- *Establishing permanent vegetation through seeding, sodding, or transfer of adult plants that are tolerant to low-nutrient mineral soils and saline moisture. Common seed types used in Florida are bahia, bermuda, bahia/bermuda mix, and annual type ryegrass. Additional seed types that are being tested by the Natural Resource Conservation Service for temporary or permanent stabilization of soil in construction areas and soon may be available for use are eastern gamagrass, lopsided indiagrass, chalky bluestem, hairawn muhly, switchgrass, and wiregrass (NRCS, 2006). Common sod types used in (but not native to) Florida are centipede, bahia, and bermuda sod.* --

What is its Purpose?

- To protect exposed soil from wind and raindrop impact.
- To provide a long-term, aesthetically pleasing, natural erosion-resistant environment during or after construction activities.

Where and How is it Commonly Used in Coastal Areas?

- Seeds that are tolerant to salt water and salt-laden moisture should be selected. In addition, chosen plants should be able to grow quickly in mineral soils with few nutrients.
- This section serves only as a guide. Consultation with an agronomist or landscape architect who is familiar with the area is highly recommended prior to selecting an appropriate plant species. Likewise, the bulk availability of the plant should be verified through the Association of Florida Native Nurseries via their website: www.afnn.org.
- In addition to the grass types listed in the description above, plant species that are native to Florida and are able to grow well in low- to high-salt environments are listed in **Table 2**.
 - Plants that are considered to have “**good**” salt tolerance are very resistant to salt drift and moisture and should be selected for highly exposed environments.
 - Plants that are considered to have “**moderate**” salt tolerance are resistant to some salt drift and moisture but should be protected by structures, fences, or more salt-tolerant plant species.
 - The geographical range in Florida is indicated by: **n** = north, **c** = central, **s** = south.
- Plant seeds can be applied by hand or hydroseeder.
- For most effective coverage, exposed soil surface should be loose (un-compacted) at time of application. Soil areas can be roughened by rolling the surface with a crimping or punching-type roller or by track walking to increase the soil surface area available for seeding.
- For best results, cover seeds or plants with a light, coarse mulch layer to keep applied seeds in place, to retain soil moisture, and to control soil temperature during seed establishment. Follow guidelines for selection and application rates for mulch under “Hydraulic Mulch” in this Appendix.
- The application of a soil binder may be necessary to stabilize hydraulic mulch and seed to allow for germination and continued growth of vegetation. Follow guidelines for binder selection and application rates under “Soil Binders” in this Appendix.
- Due to the lack of nutrients in most coastal soils, seeding may need to be used in conjunction with another control measure, such as the application of mulch and fertilizer, in order for the seeds to take hold and become effective in reducing erosion.
- Fertilizers should be used only when soil tests indicate a lack of adequate nutrients to establish and sustain the selected vegetation.
- Another method of rapid soil stabilization while allowing native plant species to develop is to lay sod along the exposed soil area and plant small, native plants by hand within small perforations of the sod. The native plants eventually over-grow and out-compete the surrounding sod for available nutrients.

Table 2. Salt-Tolerant Native Plant Species in Florida (Source: David Chiappini, 2006)

Common name	Scientific name	Area of Florida	Relative salt tolerance
Youpon Holly	<i>Ilex vomitoria</i>	n, c, s	good
Southern Red Cedar	<i>Juniperus silicicola</i>	n, c, s	good
Wax Myrtle	<i>Myrica cerifera</i>	n, c, s	good
Sand Pine	<i>Pinus clausa</i>	n, c	good
Live Oak	<i>Quercus virginiana</i>	n, c, s	good
Sand Live Oak	<i>Quercus geminata</i>	n, c, s	good
Dahoon Holly	<i>Ilex cassine</i>	n, c, s	moderate
Southern Magnolia	<i>Magnolia grandiflora</i>	n, c, s	moderate
Florida Red Bay	<i>Persea borbonia</i>	n, c	moderate
Slash Pine	<i>Pinus elliottii</i>	n, c, s	moderate
Sycamore	<i>Platanus occidentalis</i>	n, c	moderate
Chickasaw Plum	<i>Prunus angustifolia</i>	n, c	moderate
Cherry Laurel	<i>Prunus caroliniana</i>	n, c	moderate
Laurel Oak	<i>Quercus laurifolia</i>	n, c, s	moderate
Water Oak	<i>Quercus nigra</i>	n, c	moderate
Bald Cypress	<i>Taxodium distichum</i>	n, c, s	moderate
Christmas Berry	<i>Lycium carolinianum</i>	n, c, s	good
Cabbage Palm	<i>Sabal palmetto</i>	n, c, s	good
Saw Palmetto	<i>Serenoa repens</i>	n, c, s	good
Spanish Bayonet	<i>Yucca aloifolia</i>	n, c, s	good
Adams Needle	<i>Yucca filamentosa</i>	n, c, s	good
Gallberry	<i>Ilex glabra</i>	n, c, s	moderate
Paurotis Palm	<i>Acoelorrhaphe wrightii</i>	c, s	moderate
Groundseltree	<i>Baccharis halimifolia</i>	c, s	good
Devil's Backbone	<i>Pedilanthus tithymaloides</i>	c, s	moderate
Dune Sunflower	<i>Helianthus debilis</i>	n, c, s	good
Beach Morning Glory	<i>Ipomoea pes-caprae</i>	n, c, s	good
Virginia Creeper	<i>Parthenocissus quinquefolia</i>	n, c, s	good
Purslane	<i>Portulaca sp</i>	n, c, s	good
Sea Oats	<i>Uniola paniculata</i>	n, c, s	good
Coontie	<i>Zamia pumila</i>	n, c, s	good
Seaside Paspalum	<i>Paspalum vaginatum</i>	n, c, s	good
Blanket Flower	<i>Gaillardia pulchella</i>	n, c	moderate
Mahogany	<i>Swietenia mahogani</i>	s	good

Pigeon Plum	<i>Coccoloba diversifolia</i>	s	good
Satin Leaf	<i>Chrysophyllum oliviforme</i>	s	good
Silver Buttonwood	<i>Conocarpus erectus</i>	s	good
Inkberry	<i>Scaevola plumieri</i>	s	good
Marlberry	<i>Ardisia escallonioides</i>	s	good
Sea Grape	<i>Coccoloba uvifera</i>	s	good
Saltmeadow Cordgrass	<i>Spartina patens</i>	n, c, s	good
Upland River Oats	<i>Chasmanthium latifolium</i>	n, c	good
Black Mangrove	<i>Avicennia germinans</i>	n	good
Red Mangrove	<i>Rhizophora mangle</i>	n, c, s	good
White Mangrove	<i>Laguncularia racemosa</i>	c, s	good
White Stopper	<i>Eugenia axillaris</i>	c, s	good
Spanish Stopper	<i>Eugenia foetida</i>	c, s	good
Leather Fern	<i>Acrostichum danaeifolium</i>	s	good
Smooth Cordgrass	<i>Spartina alterniflora</i>	n, c	good
Sand Cordgrass	<i>Spartina bakeri</i>	n, c, s	moderate
Virginia Dropseed	<i>Sporobolus virginicus</i>	n, c, s	good
False Rosemary	<i>Conradina canescens</i>	n, c	moderate
Rusty Lyonia	<i>Lyonia ferruginea</i>	n, c	moderate
Muhly Grass	<i>Muhlenbergia capillaries</i>	n, c	moderate
Myrtle Oak	<i>Quercus myrtifolia</i>	n, c	moderate
Tough Bumelia	<i>Sideroxylon tenax</i>	n, c	moderate
Devilwood	<i>Osmanthus americanus</i>	n, c	moderate
Beautyberry	<i>Callicarpa americana</i>	n, c, s	moderate
Hercules Club	<i>Zanthoxylum clava-herculis</i>	n, c	moderate
Sparkleberry	<i>Vaccinium arboreum</i>	n, c	moderate
Railroad Vine	<i>Ipomoea pes-caprae</i>	n, c, s	good
Longleaf Pine	<i>Pinus palustris</i>	n, c	moderate
Sweetgum	<i>Liquidambar styraciflua</i>	n, c, s	moderate
Jamaica Dogwood	<i>Piscidia piscipula</i>	s	good
Blackbead	<i>Pithecellobium keyense</i>	s	good
Sea Lavender	<i>Argusia gnaphalodes</i>	s	good
Bay Cedar	<i>Suriana maritima</i>	s	good
Florida Privet	<i>Forestiera segregata</i>	n, c, s	moderate
White Indigoberry	<i>Randia aculeata</i>	c, s	moderate
Joewood	<i>Jacquinia keyensis</i>	s	moderate

When Should it be Installed?

- While construction activities are occurring.
- After construction activities are completed.

Where and When Should it not be Installed?

- Not recommended for steep slopes.
- Should not be used in areas that expect additional construction activities within 4 – 6 weeks.

What needs to be Inspected?

- Inspect area before a precipitation event to make sure it is properly protected.
- Inspect area after a precipitation event and/or heavy wind for any removal of vegetation, mulch, or other stabilization materials.

What Maintenance Activities can be Expected?

- Repair coverage and re-apply plants as needed to maintain maximum protection against erosion.
- If plant seeds fail to germinate, or established plants die, area must be re-seeded. Consider another seed type if widespread failure of plants occurs.
- The construction contractor or designer must be responsible for the health of the selected plants until they are established regardless of time and resources. The expected establishment or warranty period should be specified in the landscape plan. Once the contractor deems the vegetation established, a properly-qualified official should inspect the site and determine if additional erosion protection is needed.
- A detailed maintenance plan should be prepared by the designer or construction entity and delivered to the landowner regarding the proper care of the selected plants after establishment. The intent of plant selection and placement that was presented in the landscape plan should be re-iterated in the text of the maintenance plan.

Notes

- Transplant of adult plants can be more expensive and more labor-intensive but can provide for more protection, particularly on steeper slopes and sand dunes. The planting process for larger plants typically disturbs more soil than for smaller plants. For example, the typical planting of an adult plant requires excavating a hole that is 3 to 5 times the width of the plant's rootball (Jeff Caster, 2006). When selecting plants, carefully consider the size of the construction area, the extent of exposure of the coastal area to wind, rain, and concentrated flows, and cost of plants and labor to install plants.
- A detailed landscape plan should be prepared and approved prior to the start of construction. The landscape plan should identify location, quantity, and planting time of plants to be used for erosion control.
- If fertilizers and/or soil stabilizers are used, additional stormwater control measures must be implemented to retain materials on-site and to limit transport and contamination of adjacent water bodies.

Design Examples

Photos of Application



Sea oats (Source: Univ. of FL, 2006)



Black mangrove (Source: NRCS, 2006)

Preserving Existing Vegetation

-- *Planning construction activities so that existing trees and natural vegetated areas are avoided and protected.* --

What is its Purpose?

- To preserve existing vegetation on a construction site, thereby providing permanent soil stabilization and natural filtration of stormwater runoff.
- To provide a long-term, aesthetically-pleasing, natural erosion-resistant environment during and after construction activities.
- To limit maintenance needs by taking advantage of established vegetation.

Where and How is it Commonly Used in Coastal Areas?

- A detailed landscape plan should be prepared by a qualified person and approved prior to the start of construction. The landscape plan should clearly identify the location and quantity of vegetation to be preserved during the construction process.
- During construction, protect existing areas of vegetation that are not in direct conflict with construction activities by installing physical barriers or placing highly visible fencing.
- Planning construction activities for the height of the growing season will allow for the greatest erosion protection and visualization of the extent of existing vegetation to be protected.
- Care should be taken not to disturb tree roots.
- If roots are disturbed, they should be covered with soil and/or mulch immediately.
- For best results, cover areas immediately adjacent to existing vegetation with a thin mulch layer to help absorb erosive energy of concentrated flows caused by construction practices, to retain soil moisture, and to control soil temperature. Follow guidelines for selection and application rates for mulch under “Hydraulic Mulch” or “Compost/Wood Mulching” in this Appendix.

- The application of a soil binder may be necessary to further stabilize adjacent hydraulic mulch. Follow guidelines for binder selection and application rates under “Soil Binders” in this Appendix.
- After construction, aerate soil that is compacted from construction activities.

When Should it be Installed?

- Before construction activities begin.
- While construction activities are occurring.

Where and When Should it not be Installed?

- Not applicable.

What needs to be Inspected?

- Inspect area prior to start of construction activities to ensure vegetated areas to be avoided are properly marked and protected.
- Inspect area periodically during construction for encroachment of construction activities into protected areas and for any breach in fencing or other barrier.

What Maintenance Activities can be Expected?

- Maintain fencing and barriers as needed.
- Inspect existing vegetation for signs of stress. If needed, apply seed or transplant vegetation to maintain natural vegetative covering where possible.
- A detailed maintenance plan should be prepared by the designer or construction entity and delivered to the landowner regarding care of existing plants after construction is complete. The intent of plant preservation that was presented in the landscape plan should be re-iterated in the maintenance plan.

Notes

- After areas to be protected are marked, area available for construction activities may be limited.
- Requires additional time in the planning process to locate, mark, and plan activities around vegetated areas.

Design Examples

Photos of Application



*Natural coastal vegetation, Caribbean
(Source: University of West Indies, 2006)*



*Natural coastal vegetation in Biscayne Bay, Florida
(Source: TerraGalleria, 2006)*



*Protected tree on construction site, with fencing outside dripline
(Source: Treescape, 2006)*



*Marked tree preservation area in construction zone
(Source: National Gallery, 2006)*

Design Example

Mock Site Plan

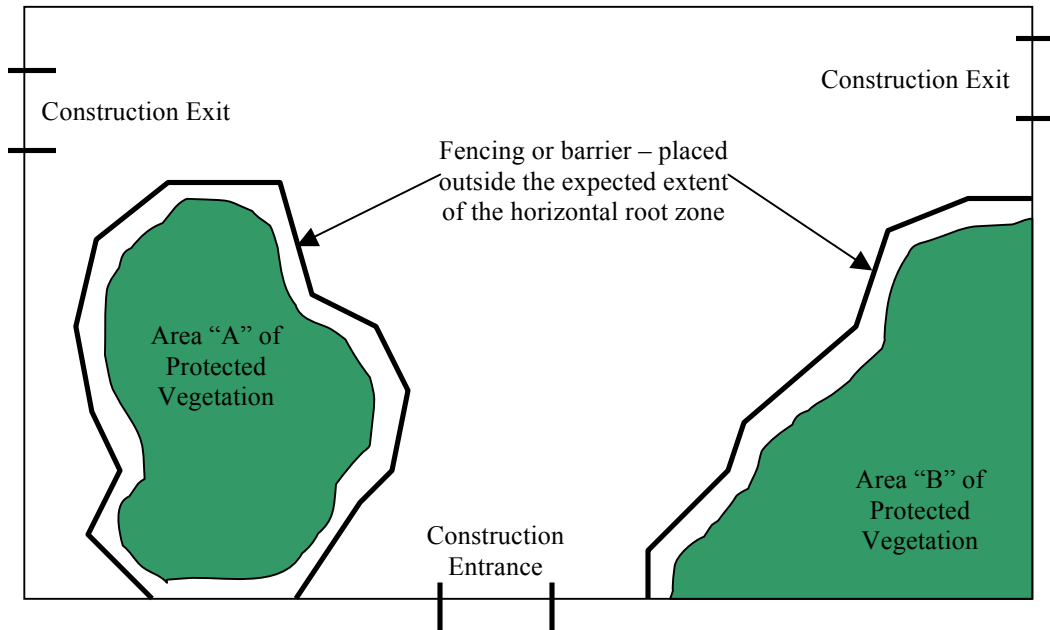

A designer on a coastal construction project wishes to protect existing coastal vegetation to limit erosion in areas that will not be graded. The designer clearly marks and fences off areas to be protected (see mock site plan). Area A includes several small trees, so the fencing is placed just outside the trees' drip lines or canopy extent, which is expected to be similar to the extent of the root zone. Area B contains a large tree, and guidelines state that protective fencing should be placed 1 foot away for every 1 inch diameter of the tree, with a minimum of 10 feet. The tree is 24 inches in diameter, so fencing is placed at least 24 feet away from the edge of the tree. Where possible, construction site entrances and exits are located well away from areas of protected vegetation.

Minimum Fencing Guidelines for Tree Protection (Source: City of Urbana, IL, 2006):

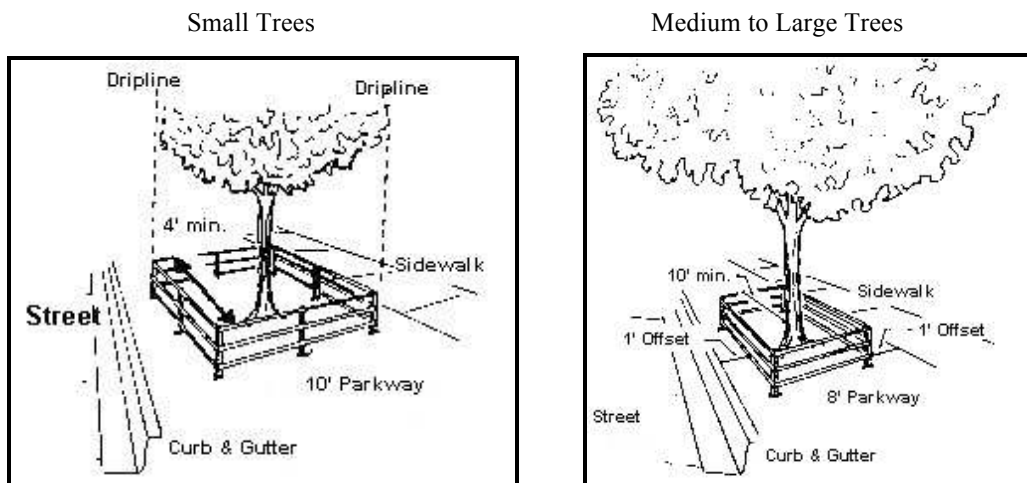

Construction Site Barrier

-- *Installing a permanent barrier at the soil/water interface to protect construction area from erosion and to limit sediment transfer to adjacent water body. Types of barriers include sheet piles, concrete walls, or earthen dikes.* --

What is its Purpose?

- To protect construction area from erosion due to waves, tides, and runoff.
- To limit sediment leaving a construction site and transfer to an adjacent water body.

Where and How is it Commonly Used in Coastal Areas?

- Barriers should be designed to provide protection over the full range of tidal fluctuations and a reasonable design storm surge.
- A temporary barrier may be placed while the permanent barrier is installed landward of the temporary barrier.
- Installation of barrier is specific to type of barrier.

When Should it be Installed?

- Before construction activities begin.
- While construction activities are occurring.

Where and When Should it not be Installed?

- In areas where coastal wildlife habitat must not be disturbed.
- In areas where the maintenance of landscape aesthetics is a priority.

What needs to be Inspected?

- Inspect area periodically during construction for any breach in barrier, particularly any breaches or openings that allow passage of water and subsequent erosion and/or transfer of sediment from construction site to water body.

What Maintenance Activities can be Expected?

- Maintain and re-construct barriers as needed.

Notes

- Area available for construction activities may be limited after placement of barrier.
- Installation of barriers may be equipment- and labor-intensive.
- Development of a plan using this method may require the professional skills of a structural engineer.

Design Examples

Photos of Application



Coastal construction along US Hwy 1, Key West, FL
(Source: James Smoot, 2006)



Protection of construction site using sheet-pile barrier and jute fiber mat (Source: Foundation Technologies, 2006)

Design Example

A designer on a coastal construction project needs to determine the expected range of tide elevations at the site over the period of construction—June 15 – September 30, 2007—to correctly locate and design a construction site barrier. The construction site is near Naples, FL.

The designer visits the National Oceanic and Atmospheric Administration (NOAA) website:

http://tidesandcurrents.noaa.gov/station_retrieve.shtml?type=Historic+Tide+Data

The designer selects a nearby tidal station by scrolling through the list of stations on the website. Once the station is selected, actual tidal data from the previous 2 days can be viewed. To pull predicted values for tide elevations for the period of construction, the designer selects the “Tide Predictions” tab on the left side of the screen (see screen capture). The designer selects the dates of the planned period of construction and can view a graphical or tabular summary of hourly tide elevations for that period.

From the predicted data for the construction period, the expected maximum high tide elevation is 3.60 feet above mean low-low water elevation. The expected minimum low tide elevation is 1.00 foot below mean low-low water elevation. Therefore, there is an expected tide range of 4.60 feet during the construction period.

The designer can specify the height of the barrier so that it rises well above the expected maximum high tide elevation to protect the construction site from erosion from waves and tides.

Another NOAA web resource for current and historical data from tidal monitoring sites is as follows:
<http://tidesonline.nos.noaa.gov/geographic.html>

Design Example, cont.

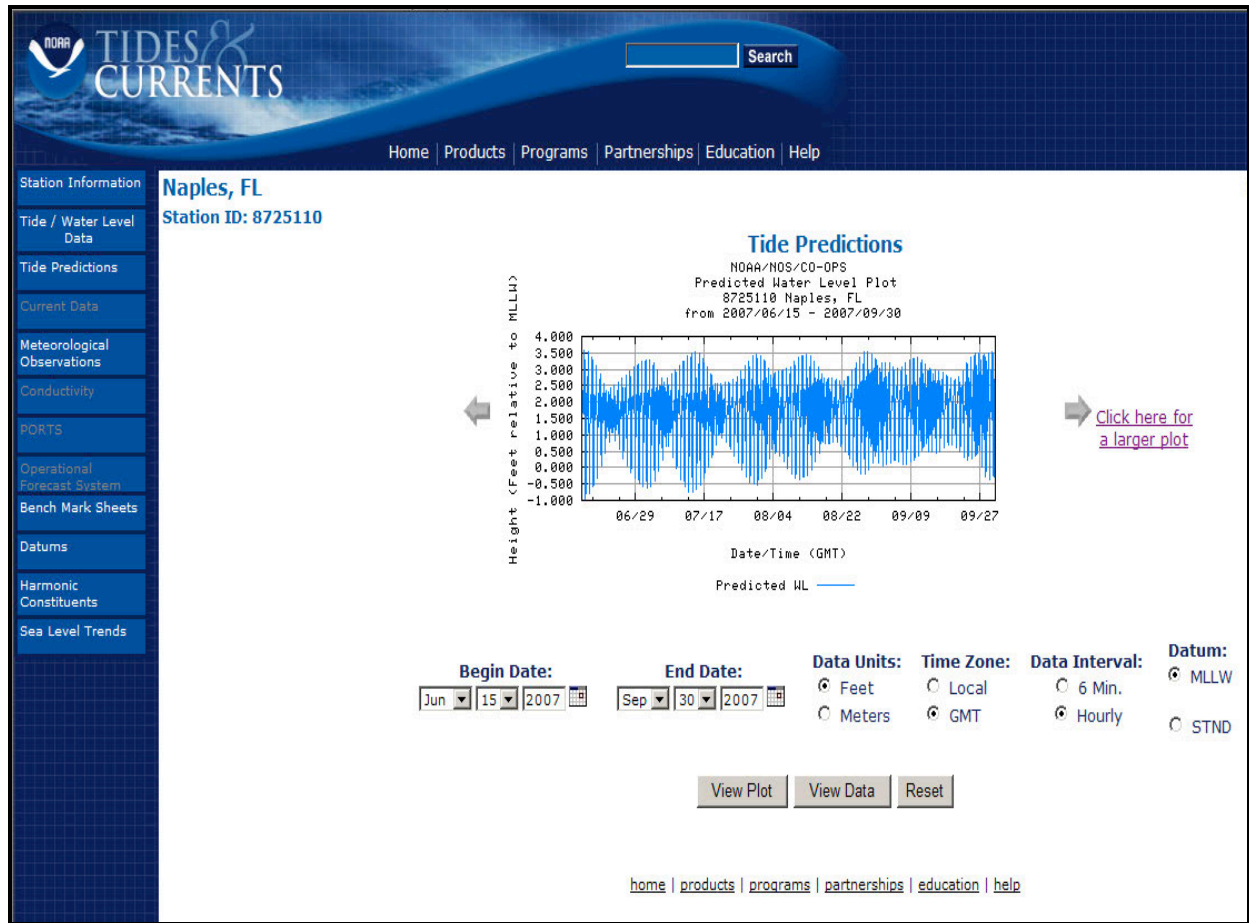

Screen capture of Tide Predictions website for tidal monitoring station #8725110 at Naples, FL (Source: NOAA, 2006)

Geotextiles, Mats, and Geogrids

-- *A natural or synthetic material used to control soil erosion from wind and water. The material can be formed into fibrous mats, blankets, soil-filled socks, or interlocking grids. Common materials include:*

- *Natural: excelsior, straw, jute, coconut fiber*
- *Synthetic: metal geogrid, polyethylene*

Seeds, fertilizers, and polymer such as polyacrylamides (PAM) can be applied in conjunction with the geomaterial. See Appendix III for further discussion of polymer flocculants. --

What is its Purpose?

- To protect construction area from erosion due to waves, tides, raindrop impact, and concentrated runoff.
- To provide a medium for the growth of seedlings when establishing permanent vegetation.

Where and How is it Commonly Used in Coastal Areas?

- Geotextiles and mats are most applicable in a coastal area not directly impacted by waves. Selected geomaterial should be resistant to saline water and moisture.
- Sand-filled geosocks can be used to protect large, sensitive construction areas from erosion and to limit sediment transfer to the water body, but should be removed after construction.
- Geotextiles and mats can be used in conjunction with an armoring technique (see “Polymer-Enhanced Armoring” in this Appendix).
- Growth of vegetation is often slow in some coastal environments due to nutrient-poor soils. Geomaterials are useful for establishing a long-term, protective growth medium for seedlings.
- In coastal areas frequented by wildlife, a geotextile without plastic netting should be used. Wildlife can become entangled in plastic or non-breakable netting.
- Site preparation and grading are critical. Geomaterials should be installed in direct, continuous contact with the underlying soil layer.
- Rocks, large vegetation, and debris should be removed from soil prior to installation of geomaterial.
- The top 2–3 inches of soil should be loosened or aerated to provide a good seed bed for vegetation establishment.
- Installation of geomaterial is highly specific to the type of material and setting.

When Should it be Installed?

- While construction activities are occurring.
- After construction activities are completed.

Where and When Should it not be Installed?

- Geogrids should not be located in areas with high recreational use due to tripping hazards.
- Cannot be used in excessively steep or rough slopes.
- Not suitable for areas with heavy pedestrian traffic.

What needs to be Inspected?

- Inspect area before a precipitation event to make sure it is properly protected.
- Inspect area after a precipitation event and/or heavy wind for any removal of geomaterial or additional cover material such as mulch.
- If staples are installed, ensure that they are securely connected and flush with the ground.
- Check any lap joints for proper overlap of materials. Ensure there are no open spaces between segments of geomaterial. Open spaces can channelize runoff and result in concentrated erosion of soil at the lap joints.

What Maintenance Activities can be Expected?

- Repair coverage and re-apply geomaterial, additional cover, and seed as needed to maintain maximum protection against erosion.
- Ensure that geomaterial maintains contact with the underlying soil.
- If plant seeds fail to germinate, or established plants die, area must be re-seeded. Consider another seed type if widespread failure of plants occurs.

Design Examples

Photos of Application



*Jute fiber geomat in Broward County, FL
(Source: Applied Polymer Systems, 2000)*



*Sandsock, sand-filled tubular geotextile
(Source: Surfrider Foundation, 2006)*

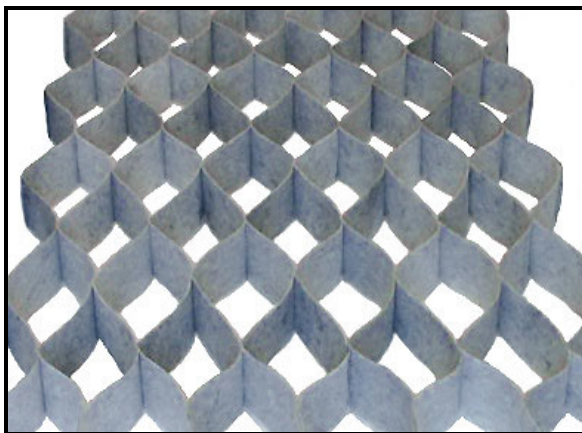

Metal geogrid (Source: IECA, 2006)



*Metal geogrid being installed for beach stabilization
(Source: IECA, 2006)*

SEDIMENT CONTAINMENT TECHNOLOGIES

Floating Turbidity Barrier

-- *A temporary silt barrier consisting of a floating tubular segment with a filter fabric extending into the water column and weighted at the bottom.* --

What is its Purpose?

- To retain sediment and floating debris from a construction area at the water's edge so that removal or containment is possible.

Where and How is it Commonly Used in Coastal Areas?

- Most applicable for use in low energy environments such as estuaries and reef-protected shorelines.
- Can also be used in relatively shallow offshore construction and excavation activities to control migration of suspended sediment.
- Floating turbidity barriers are available in three types: Type I, Type II, and Type III. All types are applicable to environments with flow velocity less than or equal to 5 feet per second. Further specifications are as follows:
 - Type I, Light Duty: Intended for low-energy environments with little or no current, wind, or wave action.
 - Type II, Moderate Duty: Intended for environments with some current (<3.5 feet per second) and with some exposure to wind.
 - Type III, Heavy Duty: Intended for environments with greater current (3.5 – 5.0 feet per second) and with moderate exposure to wind and wave action.
- The barrier should be securely anchored to shore at both ends.
- Longer-term construction projects may require that more than one line of barrier is used, as additional protection against migration of sediment and debris.
- The bottom of the barrier should be weighted by a chain or cable weighing 1.1 pounds per linear foot, and each 100 feet length of barrier requires a 24 pound anchor.
- The floating segment should be at least 6 inches in diameter.

When Should it be Installed?

- Before construction activities begin.
- While construction activities are occurring.

Where and When Should it not be Installed?

- Should not be used in high energy environments (average wave height > 1.2 *ft*).

What needs to be Inspected?

- Inspect area after a precipitation event and heavy wind for any breach in the floating barrier; check condition of shore anchors and underwater anchors.
- Migration of floating barriers is common if not properly secured and maintained.

What Maintenance Activities can be Expected?

- Breaches must be repaired immediately.
- Routinely remove large debris from the barrier to prevent breaching.
- Upon completion of construction or replacement of barrier, remove sediment and debris along with the barrier. Allow at least 24 hours after a precipitation and runoff event before removal of barrier to allow sediment time to settle.

Notes

- Removal of suspended sediment from the controlled area may be difficult and costly.
- Turbidity barrier cannot be constructed of materials that entraps or entangles wildlife, particularly manatees. Barrier must not restrict manatee access to manatee habitat.

Design Examples

Photos of Application



Turbidity barrier along US Hwy 1, Key Largo, FL
(Source: Molly Wood, 2006)



Turbidity barrier and substantial trapped sediment along
Maryland coast (Source: IECA, 2006)

Design Example

See Section III: Temporary Construction Site BMPs for design specifications on floating turbidity barriers.

Sediment Retention Barrier (SRB)

-- A temporary barrier constructed of two rows of silt fence, 4 to 6 feet apart, filled with compost, wood mulch, wood chips, or other vegetative material mixed with a polymer flocculant to enhance sediment removal. --

What is its Purpose?

- To slow runoff.
- To retain sediment and other pollutants transported in runoff, enhancing water quality of stormwater that passes through the SRB.

Where and How is it Commonly Used in Coastal Areas?

- Can be installed close to the soil/water interface or at the seaward side of construction activities to slow runoff and trap sediment from construction site.
- Used in coastal areas with water-quality concerns in addition to sediment.
- Drainage area upstream from SRB should be limited to 1 acre/100 *ft* of silt fence.
- Silt fence should allow a water passage rate of 70 *gpm/ft*².
- Filter fabric must be entrenched into underlying soil; otherwise, undercutting will occur.
- The SRB must be installed along slope at zero grade and perpendicular to flow, never up- and down-slope. Fence can channelize and divert runoff if not installed at zero grade.
- Silt fence must be installed so the top of the fence is level in order to adequately retain water and avoid fence failure.
- Ends of silt fence should be continued up-slope so runoff does not flow around ends of fence.
- Allow sufficient space up-slope from the SRB for ponding of water.
- Seams between sections of silt fence should be wrapped and rolled together and staked. See sections I through V for additional guidance.
- The loose mulch or other vegetative material placed inside the SRB should be at least 3 feet deep and should not be compacted.
- The dry polymer flocculants should be applied to and mixed with the loose mulch using a hand spreader.
- See Appendix III for further discussion of polymer flocculants and polymer-enhanced SRBs.

When Should it be Installed?

- Before construction activities begin.

Where and When Should it not be Installed?

- In areas where large volumes and rates of runoff are expected.
- Cannot be installed within the tidal zone or where contact with waves is expected.

What needs to be Inspected?

- Inspect area after a precipitation event for any tears or splits in the fabric material, movement of posts, undercutting of fabric, detachment of fabric from posts, and removal of material between the layers of silt fence.
- Inspect area after a precipitation event for buildup of sediment.

What Maintenance Activities can be Expected?

- Damaged areas must be repaired immediately.
- SRB may be removed when areas up-slope are permanently stabilized and water-quality of runoff is no longer a significant concern in the area.
- When sediment reaches one-half the height of the silt fence, the sediment should be removed.

Notes

- During larger storm events, temporary flooding can occur on the upstream side of the silt fence.
- Design life of silt fence is short (5–8 months if properly installed).

Design Examples

Photos of Application



SRB prior to placement of mulch barrier
(Source: Florida Dept. of Envr. Protection, 1988)



SRB with shredded wood mulch and polymer
(Source: Manoj Chopra, 2006)

Design Example

See Appendix III: Polymer and Alum for design specifications on SRBs.

Compost Filter Berms

-- *A temporary or permanent ridge of erosion-resistant material at the base of a slope of exposed soil or in any location where runoff of eroded soil should be restricted. Typical berm materials include shredded wood (wood chips, wood bark, wood cellulose fiber, and wood excelsior) and organic material (vegetative trimmings such as grass, shredded shrubs, and trees). Examples of compost filter berms that have been implemented in the eastern U.S. are as follows:*

- *Mesh sock stuffed with coarse bark, wood chips, fine-shredded wood or vegetal fiber suited for seed germination.*
- *Berm constructed of fine, shredded wood and other recycled organic material and installed by a patented pneumatic machine which forms, compacts, and automatically stabilizes the berm with a soil binder. --*

What is its Purpose?

- To retain eroded soil on-site.
- To restrict movement of runoff and any eroded soil.
- To channelize runoff to a desired location, perhaps directing it away from the most disturbed areas.

Where and How is it Commonly Used in Coastal Areas?

- The filter berm should be constructed near the soil/water interface in coastal areas, but care should be taken to keep the berm above the expected high tide elevations.
- Berms can be constructed above and below the areas of construction, to restrict clean water from moving over any areas of exposed soil and to restrict runoff from entering the nearby water body.
- If berm is designed to re-direct runoff, water can be channelized to a sedimentation pond or other treatment feature. Protect outlets to treatment features with riprap or vegetation, depending on the volume of runoff re-directed. See Sections I through V for additional guidance.
- Compaction of the soil/compost material is necessary.
- Minimum recommended grade of slope where berm is to be installed is 1%.
- The berm should be constructed with an ideal 1V:2H ratio to maintain stability of berm. Common berm sizes and specifications are listed in **Table 3**.
- Berms shall be installed on level contours at zero slope to ensure perpendicular sheet flow.
- If concentrated flows are expected, encase compost in a stabilizing material such as a mesh sock and stake every 10 linear feet.
- The ends of the berm must be constructed to point upslope (ends at higher elevation than remainder of berm) to prevent water from circumventing the berm.
- If possible, berms should be installed on a level surface at a distance of 5 *ft* or greater from the toe of the slope to maximize the area available for sediment deposit behind the berm. It may be necessary to install a second berm behind the initial berm to restrict flow and allow for adequate space for sediment deposit.
- Berm should be immediately seeded with salt-tolerant vegetation to reduce erosion of the berm. Follow guidelines presented under “Establishing Permanent, Salt-Tolerant Vegetation” in this Appendix.

Table 3. Compost Berm Specifications (Source: Filtrexx, 2006)

<i>Slope</i>		<i>Maximum slope length</i>	<i>Berm size required</i>	<i>Approx. berm length per cubic yard of material</i>
(percent)	(ratio, <i>V:H</i>)	(linear feet)	(height × width)	(linear <i>ft</i>)
0%-2%	flatter than 1:50	250	1 <i>ft.</i> x 2 <i>ft.</i>	19
2%-10%	1:50-1:10	125	1 <i>ft.</i> x 2 <i>ft.</i>	19
10%-20%	1:10-1:5	100	1 <i>ft.</i> x 2 <i>ft.</i>	19
20%-33%	1:5-1:3	50	1.3 <i>ft.</i> x 2.6 <i>ft.</i>	10
>50%	>1:2	25	1.5 <i>ft.</i> x 3 <i>ft.</i>	7.6

NOTE: To obtain a copy of this information, go to www.filtrexx.com; on the left side of the screen, click on Specs & Designs; then click on Compost Filter Berms-Silt Fence Alternative; then click Open when prompted; and open the Word file titled, “Filtrexx Berm SpecMaster 1-15-03.doc.” Web site and documentation are subject to change.

- Compost used for berms should have the following characteristics:
 - Free of weeds, refuse, contaminants, or other materials toxic to plant growth
 - Derived from a well-decomposed source of organic matter

- pH between 5.0 and 8.0
 - Particle size between ½” and 2” (99% passing through a 2” sieve and a minimum of 70% not passing through a 3/8” sieve)
 - Moisture content less than 60%
 - Must comply with local, state, and federal regulations.
- If on-site vegetation is used as material for the berm, ensure that invasive species such as melaleuca and Brazilian pepper are removed from the site prior to grinding or shredding of existing vegetation.
 - Application of a soil binder on the berm surface may be necessary in areas with high wind and rain exposure. Follow guidelines for selection and application rates of binders under “Soil Binders” in this Appendix.

When Should it be Installed?

- Before construction activities begin.
- While construction activities are occurring.

Where and When Should it not be Installed?

- Cannot be placed below high tide elevations.
- Should not be used in areas with high wind exposure unless a soil/compost binder is applied to maintain placement of berm.

What needs to be Inspected?

- Inspect berm after precipitation events or heavy wave action for erosion.
- Inspect berm to ensure vegetation is becoming established.

What Maintenance Activities can be Expected?

- Eroded areas must be re-filled, compacted, and re-covered with mulch immediately.
- The contractor should remove collected sediment when it reaches one-half of the exposed height of the filter berm.

Design Examples

Photos of Application



Compost filter berm in sandy soils (Source: Rexus, 2006)



Detail of compost-filled mesh sock (Source: Filtrexx, 2006)



Installation of compost berm (Source: Rexus, 2006)

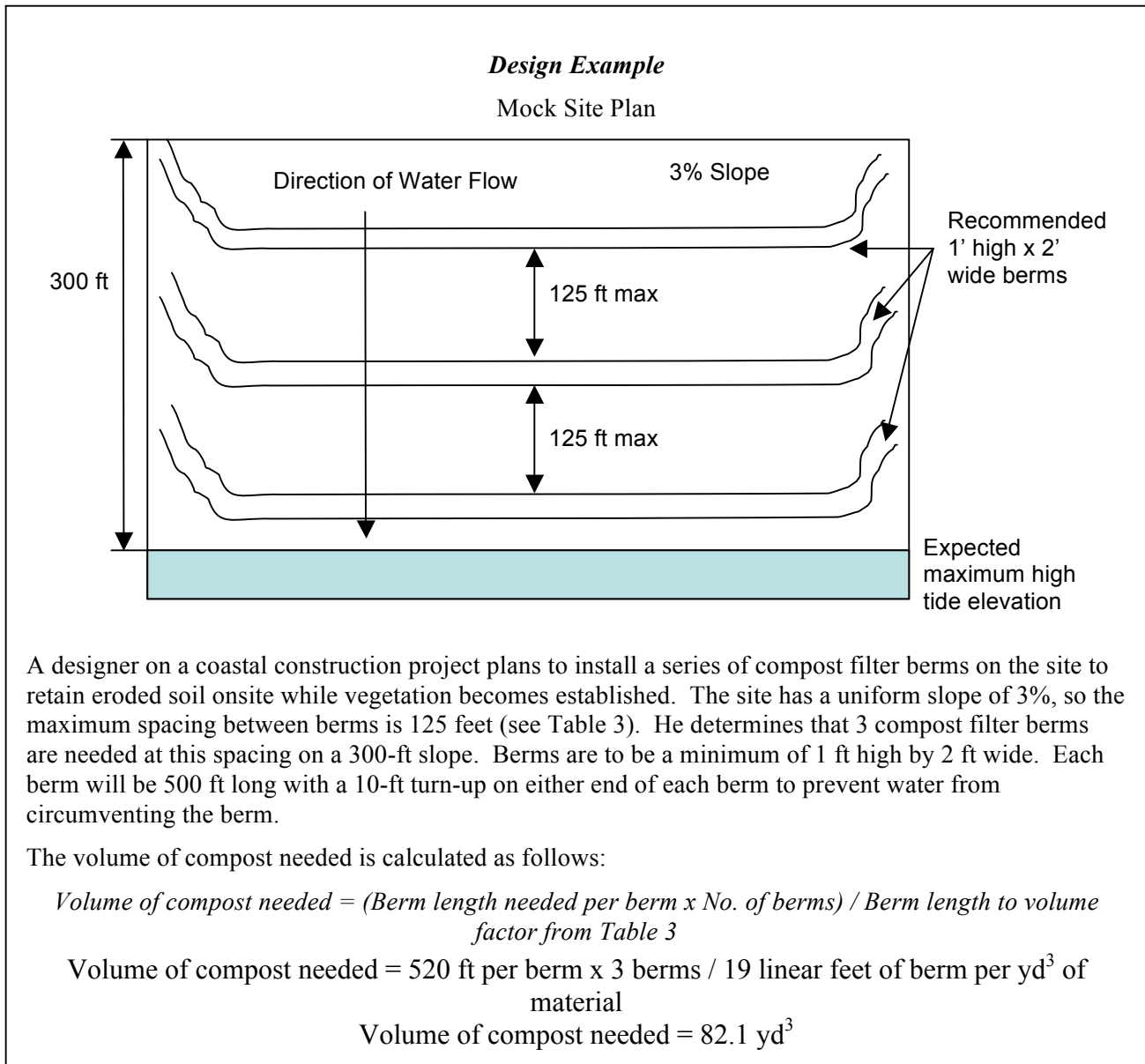

REFERENCES

1. Applied Polymer Systems, 2000, file photograph
2. Applied Polymer Systems, 2006, Website, <http://www.siltstop.com/index.html>
3. Association of Florida Native Nurseries, 2006, Website, <http://www.afnn.org>
4. Boan, Josh; Shepard, Michael; and Iwinski, Steve, 2006, US 98 Soft Armor Countermeasures Utilizing Polymer Technology, Florida Department of Transportation and Applied Polymer Systems, Presentation at the FICE/FDOT Design Conference, Orlando, FL.
5. CalTrans, 2004, California Stormwater Best Management Practices Manual, Handbook 1 of 11 (Construction).
6. Caster, Jeff, 2006, State Transportation Landscape Architect, Florida Department of Transportation, personal communication.
7. Chiappini, David, September 2006, Chiappini Farm Native Nursery, personal communication via Florida Department of Transportation.
8. Chopra, Manoj, 2006, Associate Professor, University of Central Florida, personal photograph.
9. City of Urbana, Illinois, November 2006, Website, <http://www.ci.urbana.il.us>
10. Filtrexx International, September 2006, Website, <http://www.filtrexx.com/index.htm>
11. Florida Department of Environmental Protection, 1988, The Florida Stormwater, Erosion, and Sedimentation Control Inspector's Manual.
12. Foundation Technologies, Inc., November 2006, Website, <http://www.foundationtechnologies.com/>
13. International Erosion Control Association (IECA), July 2006, Website, <http://www.ieca.org/>
14. Kennebec County Soil and Water Conservation District (KCSWCD), Kennebec, Maine, August 2006, Website, <http://www.kcswcd.org/>
15. National Oceanographic and Atmospheric Association (NOAA), August 2006, Ocean and Coastal Resource Management, Website, <http://coastalmanagement.noaa.gov/>
16. National Gallery of Art, November 2006, Site Construction Website, <http://www.nga.gov>
17. Natural Resource Conservation Service (NRCS), July 2006, U.S. Department of Agriculture, Website, <http://plant-materials.nrcs.usda.gov>
18. North Carolina Department of Environment and Natural Resources (NCDENR), August 2006, Division of Forestry Services, Website, <http://www.dfr.state.nc.us>
19. Price and Company, August 2006, Website, <http://www.priceandcompany.com/>
20. Rexius Erosion Control Systems, September 2006, Website, <http://www.ecoberm.com/>
21. RMB Craftscapes Ltd, July 2006, Website, <http://www.hydroseeding.co.uk/>
22. SoilTac Corporation, July 2006, Website, <http://www.soiltac.com>
23. Smoot, James, 2006, Regional Associate Hydrologist, U.S. Geological Survey, personal photograph.
24. Surfrider Foundation, August 2006, Website, <http://www.surfrider.org>
25. TerraGalleria, November 2006, Website, <http://terragalleria.com>

26. Terra-Mulch, November 2006, Website, <http://terra-mulch.com>
27. Treescape, November 2006, Website, <http://www.treescape.org>
28. University of Florida, July 2006, Department of Horticulture, Website, <http://hort.ufl.edu>
29. University of West Indies, Cave Hill, August 2006, Department of Pure and Applied Sciences, Website, <http://scitec.uwichill.edu.bb/>
30. Wholesale Supplies, January 2007, Website, <http://www.wholesalesupplies.com>
31. Wood, Molly, 2006, Hydrologist, U.S. Geological Survey, personal photograph.

APPENDIX II.
DEWATERING OPERATIONS

INTRODUCTION

Overview of Dewatering Operations

Dewatering operations are an important component in the construction process and receive special attention from the local water management agencies. The removal of suspended sediment and the reduction of the associated turbidity in water produced as a part of dewatering operations provide unique challenges at construction sites. This is primarily because of the possibility of adverse impacts to receiving water bodies and often because of the limited land area available for which to implement control practices. Regulators are especially concerned with the protection of nearby wetlands from drawdown effects and protecting the receiving water body from sedimentation and possible capacity limitations.

The waters associated with dewatering operations are highly variable in their quality and are associated with highly varying geological materials and other environmental influences. Construction sites in Florida are often subject to high water-table conditions and require the employment of various dewatering activities and associated practices to locally lower groundwater levels to facilitate excavation and construction activities and to manage these waters and other waters on the site.

Types of Dewatering Methods

In Florida, the following three types of dewatering methods are most commonly used:

Rim-ditching – Rim-ditching is a method where a ditch is excavated along the inside perimeter of the excavation area and a pump is used to keep the level of the ground water below the bottom surface of the excavation. This type of dewatering method is usually the least expensive of the methods, requiring only a trash pump and backhoe. However, it produces the dirtiest water, which must be treated prior to offsite discharge. While rim ditching may be the cheapest method of construction dewatering, potential costs of water treatment prior to discharge may result in much higher costs.

Sock pipe/Horizontal wells – This method of dewatering includes the installation of perforated plastic pipes, usually wrapped in geofabric, in a horizontal fashion on the inside of the excavation pit. The plastic pipes are then attached to a pump. While this method is more expensive to install than the traditional rim ditching, it does produce significantly cleaner discharge water. Initial installation of the sock pipe is limited to 15-20 feet; however, deeper dewatering depth can be achieved in phases. The use of sock pipe is limited in clay soils.

Well-point systems – This method of dewatering includes the installation of multiple shallow wells that are attached to a main collection pipe attached to a central pump. Well-point systems are typically used in linear projects such as installation of pipelines and culverts in roadways and shallow linear ponds. The cost of this method is the most expensive of the three methods; however, it produces the cleanest water.

Purpose and Overview

Presented in this appendix are technologies available to engineers, hydrologists, and construction personnel for the removal of suspended sediment and reduction of the associated turbidity in waters produced as a part of dewatering operations at construction sites in Florida. The technologies are divided into groups: Sediment Traps and Sediment Basins, Weir Tanks and Dewatering Tanks, Filters, and Chemical Treatment. The information provided for each group of technologies, as applied to dewatering operations, generally includes the following types of information:

- Description of the technology
- General application of the technology
- Limitations of the technology
- Considerations for implementation of the technology

- Inspection and maintenance needs
- Design considerations for the technology

Additional design specifications and implementation guidance for many of the presented technologies are provided in other sections of this manual (see the Table of Contents).

Description

Dewatering operations are practices that manage the discharge of turbidity when waters other than stormwater and accumulated runoff water must be removed from a work location so that construction work may be accomplished. These waters include, but are not limited to, groundwater, water from cofferdams, water diversions, and waters used during construction activities that must be removed from a work area.

Application

These practices are implemented for discharges of waters from construction sites. Practices identified in this section are also appropriate for implementation when managing the removal of accumulated rainfall excess or runoff from depressed areas at a construction site.

Limitations

- Site conditions will dictate design and use of dewatering operations.
- The controls discussed in this “best management practice” (BMP) address sediment only.
- The controls described below in this BMP only allow for minimal settling time for sediment particles. Use only when site conditions restrict the use of the other control methods.
- Dewatering operations require, and must comply with, applicable local and Florida Department of Environmental Protection (FDEP), and Water Management District (WMD) regulatory requirements. For discharges of produced ground water from a non-contaminated site activity a FDEP Generic Permit is required ([http://www.dep.state.fl.us/legal/rules/shared/62-621\(2\).doc](http://www.dep.state.fl.us/legal/rules/shared/62-621(2).doc)). For contaminated sites no Generic Permit is available and the FDEP should be contacted for applicable requirements (<http://www.dep.state.fl.us/legal/rules/rulelistnum.htm>). For WMD regulatory requirements contact the WMD with jurisdiction where the construction site is located.
- Avoid dewatering discharges, if possible, by using the water for dust control, infiltration, etc.
- Design of this BMP requires significant professional judgment and experience because of the many influencing environmental variables to consider, such as: pumping rate, depth and area of dewatering, depth to groundwater table, soil hydraulic conductivity, soil particle sizes, and many others.

Implementation

- Dewatering operations cannot be started without prior notice to and approval from FDEP and local water management districts. This includes runoff water that is co-mingled with groundwater or other water sources. Once the discharge is allowed, appropriate BMPs must be implemented to ensure the discharge complies with all permit and other regulatory requirements.
- FDEP may require a separate NPDES permit prior to the dewatering operation. These permits will have specific testing, monitoring, and discharge requirements and can take significant time to obtain.
- The flow chart shown in Figure AII-1 should be utilized to guide dewatering operations.
- Table AII-1 provides a comparison of the technologies in this appendix.
- Dewatering discharges must not cause erosion at the discharge point.

Inspection and Maintenance

- Inspect and verify that BMPs are in place prior to the commencement of activities. While activities associated with the BMP are under way, inspect daily during the rainy season and at least weekly in the non-rainy season to verify continued BMP implementation.
- Inspect BMPs subject to dewatering until all dewatering operations are completed.
- Specific maintenance requirements for each BMP are included with the description of each.
- Sediment removed during the maintenance of a dewatering device may be either spread onsite and stabilized, or disposed of at a disposal site as approved by the owner.
- Sediment that is co-mingled with other pollutants must be disposed of in accordance with all applicable laws and regulations and as approved by the owner.

A variety of methods can be used to treat turbid water during dewatering operations. A number of technologies and approaches are presented below and provide options to achieve sediment removal. The size of particles present in the sediment and the receiving water body capacity are key considerations for selecting sediment treatment option(s); in some cases, the use of multiple devices in a “treatment train” may be appropriate.

Control Technologies

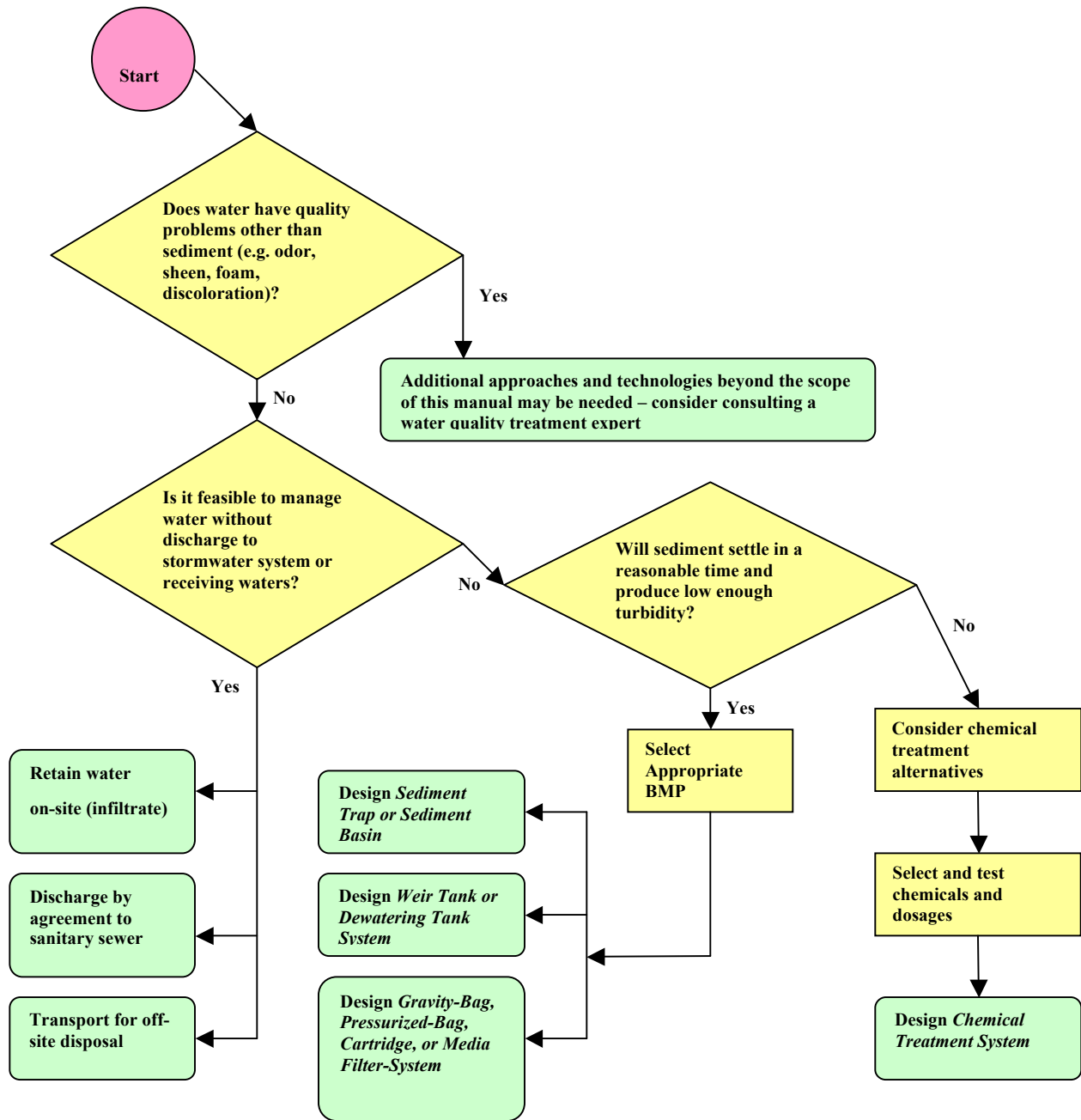

Figure AII-1. Dewatering Operations Flow Chart

Table AII-1. Comparison of dewatering technologies.

Treatment Technology Group	Treatment Technology	Pollutant Treated	Design Flow (gpm)	Footprint (sq. ft.)
<i>Sediment Traps & Sediment Basins</i>	<i>Sediment Traps</i>	<i>Sediment</i>	<i>25 to 500</i>	<i>Varies</i>
	<i>Sediment Basins</i>	<i>Sediment</i>	<i>25 to 500</i>	<i>Varies</i>
<i>Weir Tanks & Dewatering Tanks</i>	<i>Weir Tanks</i>	<i>Sediment, Metals, Oil & Grease</i>	<i>60 to 100</i>	<i>1,800</i>
	<i>Dewatering Tanks</i>	<i>Sediment, Metals, Oil & Grease</i>	<i>Varies</i>	<i>1,200 to 1,500</i>
<i>Filters</i>	<i>Gravity Bag Filter</i>	<i>Sediment and Metals</i>	<i>300 to 800</i>	<i>100 to 400</i>
	<i>Sand Media Filter</i>	<i>Sediment, Metals, BOD</i>	<i>80 to 1,000</i>	<i>17 to 450</i>
	<i>Pressurized Bag and Cartridge Filter</i>	<i>Sediment, Metals, BOD, and Hydrocarbons</i>	<i>50 to 1,000</i>	<i>200 to 320</i>
<i>Chemical Treatment</i>	<i>Continuous Chemical Treatment</i>	<i>Sediment</i>	<i>Varies</i>	<i>Varies</i>
	<i>Batch Chemical Treatment</i>	<i>Sediment</i>	<i>Varies</i>	<i>Varies</i>

Source: Caltrans, Management of Construction Site Dewatering Operations, 2006.

Sediment Traps and Sediment Basins

Sediment Trap

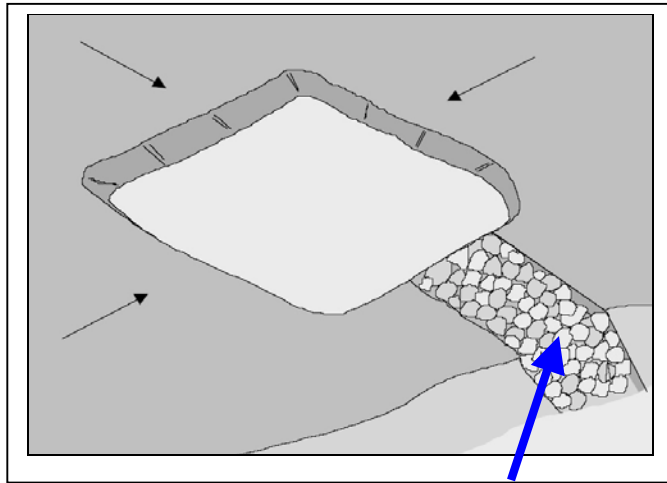

Turbidity Sampling Point Sediment Trap



Sediment Trap (Source: <http://www.mnerosion.org>)

-- A sediment trap is a temporary basin formed by excavation and/or construction of an earthen embankment or low drainage area to detain sediment-laden runoff and allow sediment to settle out before discharging. Sediment traps are generally smaller than sediment basins. --

What is its Purpose?

- Effective for the removal of large and medium sized particles (sand and gravel) and some metals that settle out with the sediment.

Where and How is it commonly Used?

- The location of the inflow pipe should be located as far away from the outfall to increase the residence time in the trap and allow more time for sediments to settle out.
- Use rock or vegetation to protect the trap outlets against erosion.
- If off-site discharge is proposed, the turbidity sampling location should be at the discharge point of the sediment trap.

What Maintenance Activities can be Expected?

- Daily inspections of sediment trap embankments and discharge point should be performed to prevent washout, scouring, and embankment blowouts.
- Removal of sediment is required when the storage volume is reduced by one-half.

Sediment Basin

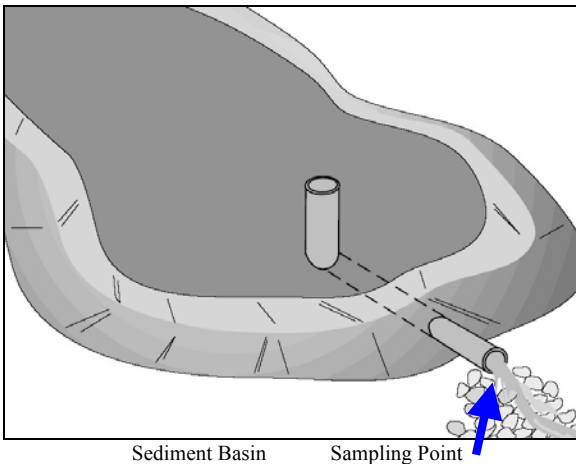

-- A sediment basin is a temporary basin with a controlled release structure that is formed by excavation or construction of an embankment to detain sediment-laden runoff and allow sediment to settle out before discharging. Sediment basins are generally larger than sediment traps. --

What is its Purpose?

- Effective for the settling of sediments such as sand, silt, and some metals that settle out with the sediment.

Where and How is it commonly Used?

- Excavation and construction of related facilities is required.
- Temporary sediment basins must be fenced if safety is a concern.
- Outlet protection is required to prevent erosion at the outfall location.
- If off-site discharge is proposed, the turbidity sampling location should be at the discharge point of the basin.

What Maintenance Activities can be Expected?

- Daily inspections of sediment basin embankments and discharge point should be performed to prevent washout, scouring, and embankment blow-outs.
- Removal of sediment is required when the storage volume is reduced by one-half.

Filters

Gravity Bag Filter

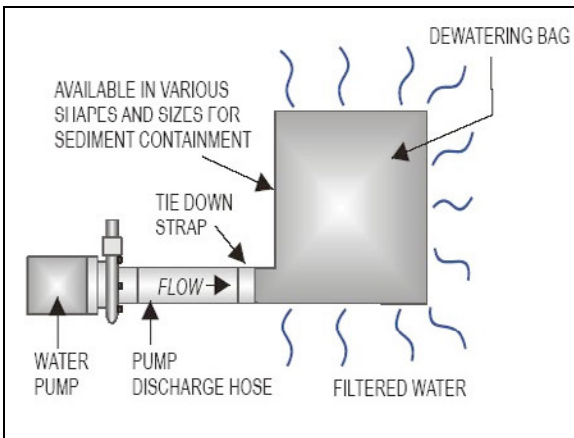

Gravity Bag Filter



Gravity Bag Filter (Source: <http://www.spillcontainment.com>)

-- A gravity bag filter, also referred to as a dewatering bag, is a square or rectangular bag made of non-woven geotextile fabric that collects sand, silt, and fines. --

What is its Purpose?

- Effective for the removal of sediments (gravel, sand, and silt). Some metals are removed with the sediment.

Where and How is it commonly Used?

- Water is pumped into one side of the bag and seeps through the bottom and sides of the bag.
- A secondary barrier, such as a rock filter bed or geo barrier, is placed beneath and beyond the edges of the bag to capture sediments that escape the bag.

What Maintenance Activities can be Expected?

- Inspection of the flow conditions, bag condition, bag capacity, and the secondary barrier is required.
- Replace the bag when it no longer filters sediment or passes water at a reasonable rate.
- The bag is disposed of offsite.

Where and When Should it not be Used?

- Based on the velocity of water passing through the bag, the seams of the bag may fail.

Weir Tanks and Dewatering Tanks

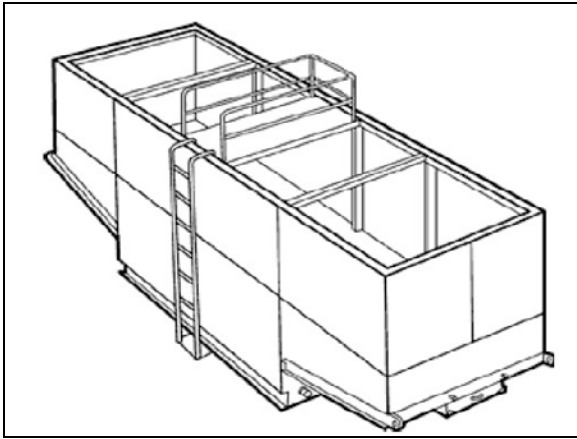

Weir Tank (Baker Tank) (Source: <http://www.dot.ca.gov>)



Dewatering Tank (Source: <http://www.dot.ca.gov>)

Weir Tanks

-- A weir tank separates water and waste by using weirs. The configuration of the weirs (over and under weirs) maximizes the residence time in the tank and determines the waste to be removed from the water, such as oil, grease, and sediments. --

What is its Purpose?

- The tank removes trash, some settleable solids (gravel, sand, and silt), some visible oil and grease, and some metals (removed with sediment). To achieve high levels of flow, multiple tanks can be used in parallel. If additional treatment is desired, the tanks can be placed in series or as pre-treatment for other methods.

Where and How is it commonly Used?

- Tanks are delivered to the site by the vendor, who can provide assistance with set-up and operation.
- Tank size will depend on flow volume, constituents of concern, and residency period required. Vendors should be consulted to appropriately size tank.

What Maintenance Activities can be Expected?

- Periodic cleaning is required based on visual inspection or reduced flow.
- Oil and grease disposal must be by licensed waste disposal company.

Dewatering Tanks

-- A dewatering tank removes debris and sediment. Flow enters the tank through the top, passes through a fabric filter, and is discharged through the bottom of the tank. The filter separates the solids from the liquids. --

What is its Purpose?

- The tank removes trash, gravel, sand, and silt, some visible oil and grease, and some metals (removed with sediment). To achieve high levels of flow, multiple tanks can be used in parallel. If additional treatment is desired, the tanks can be placed in series or as pretreatment for other methods.

Where and How is it commonly Used?

- Tanks are delivered to the site by the vendor, who can provide assistance with set-up and operation.
- Tank size will depend on flow volume, constituents of concern, and residency period required. Vendors should be consulted to appropriately size tank.

What Maintenance Activities can be Expected?

- Periodic cleaning is required based on visual inspection or reduced flow.
- Oil and grease disposal must be by licensed waste disposal company.

The following methods are generally used when land is a limiting factor. These are generally very costly, so the Designer is encouraged to seek out the most cost effective method.

Sand Media Filter



Sand Media Particulate Filter

(Source: <http://www.dot.ca.gov>)



Sand Media Particulate Filter

(Source: <http://www.spillcontainment.com>)

-- Water is treated by passing it through canisters filled with sand media. Generally, sand filters provide a final level of treatment. They are often used as a secondary or higher level of treatment after a significant amount of sediment and other pollutants have been removed using other methods. --

What is its Purpose?

- Effective for the removal of trash, gravel, sand, and silt and some metals, as well as the reduction of biochemical oxygen demand (BOD) and turbidity.
- Sand filters can be used for stand-alone treatment or in conjunction with bag and cartridge filtration if further treatment is required.
- Sand filters can also be used to provide additional treatment to water treated by settling or basic filtration.

Where and How is it commonly Used?

- The filters require delivery to the site and initial set up. The vendor can provide assistance with installation and operation.

What Maintenance Activities can be Expected?

- The filters require regular service to monitor and maintain the level of the sand media. If subjected to high loading rates, filters can plug quickly.
- Vendors generally provide data on maximum head loss through the filter. The filter should be monitored daily while in use, and cleaned when head loss reaches target levels.
- If cleaned by backwashing, the backwash water may need to be hauled away for disposal, or returned to the upper end of the treatment train for another pass through the series of dewatering BMPs.

Pressurized Bag and Cartridge Filters



Pressurized Bag Filter

(Source: <http://www.dot.ca.gov>)



Cartridge Filter

(Source: <http://www.dot.ca.gov>)

-- A pressurized bag filter is a unit composed of single filter bags made from polyester felt material. The water filters through the unit and is discharged through a header. Vendors provide bag filters in a variety of configurations. Some units include a combination of bag filters and cartridge filters for enhanced contaminant removal. --

-- Cartridge filters provide a high degree of pollutant removal by utilizing a number of individual cartridges as part of a larger filtering unit. They are often used as a secondary or higher (polishing) level of treatment after a significant amount of sediment and other pollutants are removed. Units come with various cartridge configurations (for use in series with bag filters) or with a larger single cartridge filtration unit (with multiple filters within). --

What is its Purpose?

- Effective for the removal of sediment (sand, silt, and some clays) and some metals, as well as the reduction of BOD, turbidity, and hydrocarbons. Oil absorbent bags are available for hydrocarbon removal.
- Filters can be used to provide secondary treatment to water treated via settling or basic filtration.
- Hydrocarbons can often be removed with special resin cartridges.

Where and How is it commonly Used?

- The filters require delivery to the site and initial set up. The vendor can provide assistance with installation and operation.

What Maintenance Activities can be Expected?

- The filter bags require replacement when the pressure differential equals or exceeds the manufacturer's recommendation.
- The cartridges require replacement when the pressure differential equals or exceeds the manufacturer's recommendation.

Chemical Treatment

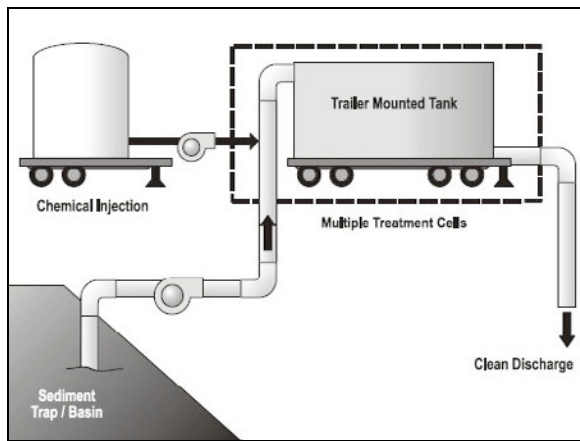

From a holding area using Alum

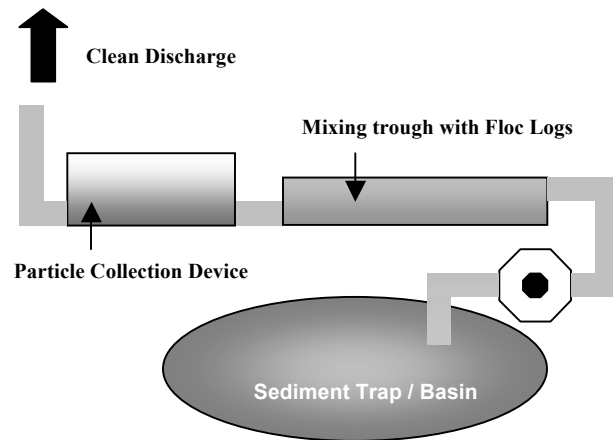

Using in-line mixing with a Flocc Log

-- Chemical treatment includes the application of carefully selected chemicals such as polymers (e.g. PAM), alum, and other flocculants to waters to aid in the reduction of turbidity by more efficient removal of fine suspended sediment. – also see Appendix III for additional chemical applications.

What is its Purpose?

- Appropriate chemical treatment can reliably provide exceptional reductions of turbidity and associated pollutants and should be considered where turbid discharges to sensitive waters cannot be avoided using other available BMPs.

Where and How is it commonly Used?

- The use of chemical treatment must have the pre-approval of FDEP
- Sediment basins or trailer-mounted unit can be designed for chemical application
- Treatment systems can be designed to be flow-through continuous or batch-treatment systems
- May require large area
- Limited discharge rates depending on receiving water body
- Operation and maintenance requirements need to be considered in the design
- Requires monitoring for non-visible pollutants

What Maintenance Activities can be Expected?

- Turbidity is difficult to control if fine particles are suspended in dewatering waters from a construction site. Sedimentation ponds are effective at removing larger particulate matter by gravity settling, but are ineffective at removing smaller particulates such as clay and fine silt. Sediment ponds are typically designed to remove sediment no smaller than medium silt (0.02 mm). Chemical treatment may be used to reduce the turbidity of waters to be discharged. Turbidities need to be reduced to levels less than 29 NTUs above the background.
- Chemically treated waters to be discharged from construction sites must be non-toxic to aquatic organisms. The following protocol should be used to evaluate chemicals proposed for use in treatment at construction sites. Authorization to use a chemical in the field based on this protocol does not relieve the applicant from responsibility for meeting all discharge and receiving water criteria applicable to a site.
 - Treatment chemicals must be approved by FDEP and EPA for potable water use.

- Prior to authorization for field use, laboratory batch tests should be conducted to demonstrate that turbidity reduction necessary to meet the receiving water criteria could be achieved. Test conditions, including but not limited to raw water quality and laboratory test procedures should be indicative of field conditions. Although these small-scale tests cannot be expected to reproduce performance under field conditions, they are indicative of treatment capability. Testing should use water from the construction site at which the treatment chemical is proposed for use.
- Prior to authorization for field use, the chemical treatment should be tested for aquatic toxicity using a “worst case scenario” of whole product release. Whole Effluent Toxicity testing and limits (ASTM WET test procedures), should be used.
- The proposed maximum dosage should be at least a factor of five lower than the No Observed Effects Concentration (NOEC).
- The approval of a proposed treatment chemical should be conditional, subject to full-scale bioassay monitoring of treated waters at the construction site where the proposed treatment chemical is to be used.
- Treatment chemicals that have already passed the above testing protocol do not need to be reevaluated. Contact the FDEP for a list of treatment chemicals that may be approved for use.

How Should it be Designed?

- The design and operation of a chemical treatment system should take into consideration the factors that determine optimum, cost-effective performance. It may not be possible to fully incorporate all of the classic concepts into the design because of practical limitations at construction sites. Nonetheless, it is important to recognize the following:
 - The **right** chemical must be used at the **right** dosage. A dosage that is either too low or too high is not likely to produce the lowest turbidity. There is usually an optimum dosage rate.
 - The flocculant must be mixed rapidly into the water to insure proper dispersion.
 - Sufficient flocculation might occur in the pipe leading from the point of chemical addition to the settling or sediment basin.
 - Chemical Treatment Systems require mixing of the chemical and the turbid water to cause flocculation to occur. The size and volume of the treatment system may be restricted to provide adequate mixing.
 - Care must be taken in the design of the withdrawal system to minimize outflow velocities and to prevent floc discharge. If possible, the discharge should be directed through a physical filter such as vegetated swale that would catch any unintended floc discharge.
 - A pH-adjusting chemical should be added into the sediment basin, if needed, to control *pH*.

CTS-1 Continuous Treatment

What is its Purpose?

- Chemical Treatment Systems can be designed as flow-through continuous treatment systems.
- These systems consist of the collection system, a chemical mixing system (where the chemical is mixed with the turbid water), sediment collection device, and interconnecting conveyances.
- It may include a pump or pumps, to help convey the turbid water through the treatment system; however, these are not always required.
- Primary sediment basins, or grit pits, may be required if the water to be treated has a high percentage of suspended solids to prevent sediment from burying the treatment system and reducing its efficiency.

Where and How is it commonly Used?

- The size of the continuous treatment system has to allow for continuous mixing for the length of time required to complete the CTS reaction at the flow rate expected through the system.
- The combination of any holding areas and treatment system capacity should be large enough to treat the volume of water anticipated.
- The TSS of the water running through the treatment system is not to exceed 4% suspended solids or a turbidity reading greater than 40,000 *NTU*.
- Primary settling should be encouraged in a sediment basin or sediment trap if the suspended solids load is above this level.
- On sites where the suspended solids load heading to the treatment system is below this level sediment basins or sediment traps are not required for normal flow conditions, but some sort of particle collection device should be installed to prevent sediment deposition in the treatment system due to heavy rain events.
- The following discharge flow rate limits apply absent any local requirements:
 - If the discharge is direct or indirect to a stream, the discharge flow rate should not exceed 50 percent of the peak flow rate for all events between the 2-year and the 10-year, 24-hour event.
 - If discharge is occurring during a storm event equal to or greater than the 10-year storm the allowable discharge rate is the peak flow rate of the 10-year, 24-hour event.
 - Discharge to a stream should not increase the stream flow rate by more than 10 percent.
 - If the discharge is directly to a lake or major receiving water there is no discharge flow limit.
 - If the discharge is to a municipal storm drainage system, the allowable discharge rate may be limited by the capacity of the public system. It may be necessary to clean the municipal storm drainage system prior to the start of the discharge to prevent scouring solids from the drainage system.

What Maintenance Activities can be expected?

- Inspect the flow-through treatment system at least daily and after rain events of ½ inch or greater, taking care to ensure the chemical treatment products are in place, moist, and have not been buried by sediment.
- Inspect, repair, and clean out the sediment collection devices as needed to keep the system working at peak efficiency.
- Compliance Monitoring:
 - *pH* and turbidity of the treated water
 - *pH* and turbidity of the receiving water
- Discharge Compliance:
 - Treated water must be sampled and tested for compliance with *pH* and turbidity limits at least two times per day. These limits may be established by the water quality standards or a site-specific discharge permit.
 - Sampling and testing for other pollutants may also be necessary at some sites.
 - Turbidity must be within 29 *NTU* of the background turbidity. Background is measured in the receiving water, upstream from the treatment process discharge point.
 - The *pH* must be within the range of 6.5 to 8.5 standard units and not cause a change in the *pH* of the receiving water of more than 0.2 standard units.
 - It is often possible to discharge treated water that has a lower turbidity than the receiving water and that matches the *pH*.
 - Treated water samples and measurements should be taken from the point of discharge.
 - Compliance with the water quality standards is determined in the receiving water.

- Sediment Removal and Disposal:
 - Flocculated sediment should be removed from the sediment collection devices as necessary. Treated sediment can be disposed of in a landfill or can be used as a topsoil amendment elsewhere on the site to help prevent erosion and enhance vegetation establishment.
 - Flocculated sediment should never be used as structural fill material.

CTS-2 Batch Treatment

What is its Purpose?

- Chemical treatment systems can be designed as batch treatment systems using either ponds or portable trailer-mounted tanks.
- This chemical treatment system consists of the collection system, a sediment basin or sediment trap, pumps, a chemical feed system, treatment cells, and interconnecting piping.

Where and How is it commonly Used?

- The treatment system should use a minimum of two lined treatment cells. Multiple treatment cells allow for clarification of treated water while other cells are being filled or emptied.
- Treatment cells may be basins, traps or tanks. Portable tanks may also be suitable for some sites.
- The following equipment should be located in an operation shed:
 - The chemical injector
 - Secondary contaminant for acid, caustic, buffering compound, and treatment chemical
 - Emergency shower and eyewash
 - Monitoring equipment which consists of a *pH* meter and a turbidimeter
- Sizing Criteria:
 - The combination of the sediment basin or other holding area and treatment capacity should be large enough to treat the volume of water anticipated.
 - Bypass should be provided around the chemical treatment system to accommodate extreme storm events.
 - Primary settling should be encouraged in the sediment basin/storage pond. A “fore bay” with access for maintenance may be beneficial.
 - There are two opposing considerations in sizing the treatment cells. A larger cell is able to treat a larger volume of water each time a batch is processed. However, the larger the cell the longer the time required to empty the cell. A larger cell may also be less effective at flocculation and therefore require a longer settling time.
 - The simplest approach to sizing the treatment cell is to multiply the allowable discharge flow rate times the desired drawdown time. A 4-hour drawdown time allows one batch per cell per 8-hour work period, given 1 hour of flocculation followed by 2 hours of settling.
 - The permissible discharge rate governed by potential downstream effect can be used to calculate the recommended size of the treatment cells.

- The following discharge flow rate limits apply absent any local requirements:
 - If the discharge is direct or indirect to a stream, the discharge flow rate should not exceed 50 percent of the peak flow rate for all events between the 2-year and the 10-year, 24-hour event.
 - If discharge is occurring during a storm event equal to or greater than the 10-year storm the allowable discharge rate is limited to the peak flow rate of the 10-year, 24-hour event.
 - Discharge to a stream should not increase the stream flow rate by more than 10 %.
 - If the discharge is directly to a lake or major receiving water there is no discharge flow limit.
 - If the discharge is to a municipal storm drainage system, the allowable discharge rate may be limited by the capacity of the public system. It may be necessary to clean the municipal storm drainage system prior to the start of the discharge to prevent scouring solids from the drainage system.

What Maintenance Activities can be Expected?

- Chemical treatment systems must be operated and maintained by individuals with expertise in their use.
- Chemical treatment systems should be monitored continuously while in use.
- Test results should be recorded on a daily log kept on site.
- Operational Monitoring:
 - *pH*, conductivity (as a surrogate for alkalinity), turbidity, and temperature of the untreated water
 - Total volume treated and discharged
 - Discharge time and flow rate
 - Type and amount of chemical used for *pH* adjustment
 - Amount of polymer, alum, or other flocculant used for treatment
 - Settling time
- Compliance Monitoring:
 - *pH* and turbidity of the treated water
 - *pH* and turbidity of the receiving water
- Bio-monitoring:
 - Treated water should be tested for acute (lethal) toxicity. Bioassays should be conducted by a laboratory approved by the State of Florida. ***The performance standard for acute toxicity has no statistically significant difference in survival between the control and 100 percent chemically treated water.*** Acute toxicity tests should be conducted with the following species and protocols (or others approved by the State):
 - Fin Fish; fathead minnow, *Pimephales promelas* or rainbow trout, *Oncorhynchus mykiss*.
 - Water fleas; *Ceriodaphnia dubia*, *Daphnia pulex*, or *Daphnia magna*
 - All toxicity tests should meet quality assurance criteria and test conditions in the most recent version of the EPA test method (EPA-821-R-02-012). Bioassays should be performed on the first five batches and on every tenth batch thereafter or as otherwise approved by the State. Failure to meet the performance standard should be immediately reported to the State.
- Discharge Compliance:
 - ***Prior to discharge, each batch of treated water must be sampled and tested for compliance with pH and turbidity limits.*** These limits may be established by the water quality standards or a site-specific discharge permit. Sampling and testing for other pollutants may also be necessary at some sites. Turbidity must be within 29 NTUs of the background turbidity.

Background is measured in the receiving water, upstream from the treatment process discharge point. *pH* must be within the range of 6.5 to 8.5 standard units and not cause a change in the pH of the receiving water of more than 0.2 standard units. It is often possible to discharge treated water that has a lower turbidity than the receiving water and that matches the *pH*. Treated water samples and measurements should be taken from the discharge pipe or another location representative of the nature of the treated water discharge. Samples used for determining compliance with the water quality standards in the receiving water should not be taken from the treatment pond to decanting. Compliance with the water quality standards is determined in the receiving water.

- Operator Training:
 - Each contractor who intends to use chemical treatment should be trained by an experienced contractor on an active site for at least 40 hours.
- Sediment Removal and Disposal:
 - Sediment should be removed from the storage or treatment cells as necessary. Sediment remaining in the cells between batches may enhance the settling process and reduce the required chemical dosage.

REFERENCES

1. California Stormwater BMP Handbook 1 of 11 (Construction), 2003
2. UltraTech International, Inc., Compliance Products for Stormwater Management, (<http://www.spillcontainment.com>), 2006.
3. Minnesota Erosion Control Association, (<http://www.mnerosion.org>), 2006.
4. Caltrans, Management of Construction Site Dewatering Operations, (<http://www.dot.ca.gov/hq/construc/stormwater/dewateringclass.pdf>), 2006.

This page intentionally left blank

APPENDIX III
POLYMERS AND ALUM

INTRODUCTION

Overview of Polymers and Alum

On construction projects, water can be turbid and some of the turbidity cannot be removed by standard practices. Polymers and alum can be used to reduce turbidity and other pollutants. Water can be treated to remove turbidity, and other water quality indicators, such as, color and bacteria. Early research into filtration made it apparent that it alone was not enough to produce clear water. In fact, experience has demonstrated that direct filtration is largely ineffective in removing bacteria, viruses, soil particles and color. The soil particles, bacteria and viruses all contribute to the turbidity of the water.

Coagulation is related to the removal of colloidal particles and is defined as the process that causes the colloids to approach and adhere to each other to form larger particles, or flocs. Coagulation and subsequent flocculation turns the smaller particles of turbidity, color and bacteria into larger flocs, either as precipitates or suspended particles. These flocs can then be readily removed.

During coagulation a positive ion is added to water to reduce the surface charge to the point where the particles are not repelled from each other. A coagulant is the chemical substance that is introduced into the water to accomplish this. Anionic polymers can act as coagulants by “bridging” cationic molecules (Ca^{++}), this mechanism allows the anionic polymers to perform as a coagulant without the aquatic toxicity potential associated with industrial cationic coagulants. There are three key properties of a coagulant:

- a. Cations – these are most effective at neutralizing the net negative charge in natural water. (Cationic polymers have high toxicity potentials to aquatic organisms.)
- b. Nontoxic – this is needed to produce safe water.
- c. Insoluble in neutral pH range – the coagulant must precipitate out of solution so that high concentrations of the ion are not left in the water. Such precipitation assists in the colloidal removal process.

Examples of coagulants and flocculants are Polyacrylamide (PAM and PAM blends), Dual-polymer Systems, Aluminum (Al^{3+}) in the form of dry or liquid Alum, and ferric iron (Fe^{3+}) in the form of sulfate salt or chloride salt. Since Polyacrylamides are used in erosion and sediment control more than other coagulants, it will be discussed first, followed by the use of alum and other chemical coagulant forms.

Purpose and Overview

This appendix presents technologies available to engineers, hydrologists, and construction personnel for the use of polymers, polymer blends and alum in erosion and sedimentation control techniques in Florida. The appendix is divided into three sections, PAMs, Alum and Dual-Polymer systems. Temporary and permanent control technologies are presented for each section. The information provided for each technology includes:

- A description of the technology
- The general purpose(s) of the technology
- Considerations for implementation of the technology
- When the technology should be implemented
- Where and when the technology should not be used
- Inspection and maintenance needs

Additional specifications and steps for implementation of many of the technologies are provided in sections I - V.

POLYACRYLAMIDES (PAM and PAM Blends)

Polyacrylamides (PAM and PAM blends)

What is its Purpose?

- To reduce soil erosion through soil binding.
- As a water treatment additive to remove suspended particles from runoff.
- To provide an appropriate medium for the growth of vegetation for further stabilization.
- Increases infiltration through increasing particle size and pore spaces.

Where and How is it Commonly Used?

- PAM is suitable for use on disturbed soil areas that discharge to a sediment trap or sediment basin.
- PAM is typically used in conjunction with other BMPs to increase their performance.
- It can be applied to the following areas – rough graded soils, final graded soils before application of stabilization, temporary haul roads prior to placing crushed rock surfacing, compacted soils road base, construction staging and materials storage areas, soil stockpiles and areas to be mulched.
- PAM may be applied in dissolved form with water, or it may be applied in dry, granular, or powdered form. It may also be placed in the form of floc logs for passive dosing and for water quality improvement.
- Higher concentrations of PAM do not provide any additional effectiveness.

When Should it be Installed?

- While construction activities are occurring.
- PAM must be reapplied on actively worked areas if PAM is to remain effective. Reapplication is not required unless PAM treated soil is disturbed or unless turbidity levels show the need. Undisturbed soils treated with PAM may require reapplication after 2 months.

Where and When Should it not be Installed?

- If there is a potential of equipment clogging.
- Where it violates toxicity requirements.

What Needs to be Inspected?

- Visual observation of floc particles in the discharge.

What Maintenance Activities can be expected?

- Reapply PAM to disturbed or tilled areas that require continued erosion control.
- Rinse all PAM mixing and application equipment thoroughly with water to avoid formation of PAM residues.
- Downstream deposition from the use of PAM may require periodic sediment removal to maintain normal functions.

NOTES

1. Introduction

PAM is a water-soluble anionic polyacrylamide product used to minimize soil erosion caused by water and wind. It can also be used to decrease loss by binding soil particles, especially clays, which will hold them on site. In addition, these types of materials may also be used as a water treatment additive to remove suspended particles from runoff. Polyacrylamides can be used in several forms:

- Powder
- Powder added to water (wet, as a stock solution)
- Emulsion
- Gel Blocks or Bricks

Flocculation with polymers has been extensively used within the mining industry (Carter & Schiener, 1991) and recently has begun expanding into the erosion and sediment control industries. Greater scrutiny of NPDES phase II requirements has increased the demand for higher water quality discharges within both of these industries. Conventional mechanical runoff BMPs have shown limited or non-compliant capability to remove or reduce dissolved nutrients, colloidal clay and metal contamination from construction site discharges. The colloidal constituents within runoff and construction site discharges have driven the Designer to expand the scope for the use of chemical treatment systems.

Engineering designs using Stokes Law have adequately addressed the heavier particulate but continue to fail in the removal or adequate reduction of the colloidal fractions and metals (Erwin, 1978).

Environmentally safe polymer and polymer-coagulant combinations have shown significant reductions of metals (Iwinski, 1995; 2006), nutrient (Chastain, et al., 2004) and colloidal clays (Sojka, et al., 2003). A large variety of pipe mixing systems are now in use to employ these new polymer mixes into the contaminated water streams enabling engineers and construction groups to maintain compliant water quality discharges. Gowdy, et al., (2006) presented a paper at the REMTECH conference on cost-effective and efficient methodologies utilizing water-soluble PAM to routinely reduce erosion and runoff turbidity by over 95%. Resultant soil particles are flocculated, agglomerated and chelated in-situ, with significantly reduced suspended solids, metals, TMDLs and NTU values of runoff waters entering riparian water bodies.

Anionic polyacrylamide type polymers (PAMs) have become the most common materials used for water clarification and erosion control on construction sites and in sedimentation treatment systems. PAM-type polymers and blends have become highly specific for each application due to the complexity of clay variants and colloidal elements within the contaminated waters to be treated. This is not a new concept and has been widely used in other industries including erosion control in which specific polymer types are used to achieve best performance (Green and Stott, 1999). PAMs have recently been used for treatment of lagoon effluent from livestock operations (Flanagan and Canady, 2006). They studied the effect of using anionic PAM in the wastewater irrigation on reducing the losses of soluble and total nutrients (nitrogen and phosphorus) from soil. The study found that the PAM addition was effective in reducing losses of soluble ammonium nitrogen (up to 92%), soluble phosphorus (up to 71%), and also reduced total (sediment-bound) nutrient losses.

The most common methods previously used are the application of a spray or dry powder application to a disturbed soil surface to reduce the solubility of the clays into the runoff water at the source, although this has limited effect on water that has escaped from areas outside the treated soils. This method may

be the most effective in reducing the bulk of clayey particulate (Sojka, et al., 2003) although most PAMs that are used today are marketed as a “one PAM fits all” method. This method works poorly as PAMs must be tested for each clay type found in the soil, similar to procedures used in conventional water treatment industries. Improperly applied or incorrect PAMs will detach and escape from the soil surface and move into the receiving waters sometimes causing greater water quality issues than that of elevated turbidity of the runoff water alone.

Cationic PAM and chitosan have a very limited use due to the highly toxic potential to aquatic organisms. These materials must be used under highly controlled conditions and never allowed to discharge to riparian water systems without significant filtration. Cationic PAMs or biopolymers derived from chitin have shown significant toxicity issues to aquatic organisms (Orme and Kegley, 2004) and their use is commonly prohibited for most in-situ applications. Increased scrutiny of cationic polymers and chitosan is becoming more common as engineers and contractors become aware of the potential risks, technical guidelines and law. (Alabama Handbook, 2003; Georgia Soil Water Conservation Commission, 2000; Virginia Erosion & Sediment Control Handbook n.d.)

When PAM is used on construction sites in the southeast it is typically applied with temporary seeding and or mulching on areas where the timely establishment of temporary erosion control is so critical that seeding and mulching need additional reinforcement. It may be used alone on sites where no disturbances will occur until site work is continued and channel erosion is not a significant potential problem. Permanent grassing applications can be better established using PAM as a tackifier and soil conditioner.

PAMs are manufactured in various forms to be used on specific soil types, and are generally applied at a rate of up to 50 pounds/acre for dry products and 2 ½ gallons/acre of emulsion-liquid products. Using the wrong form of a PAM on a soil will result in some degree of performance failure, and increase the potential for this material to enter surface waters. PAM used alone may not reduce NTU values significantly, resulting in noncompliant water quality discharges or poor soil binding conditions. Site specific soil-PAM testing must be performed. Exceeding the maximum application rates for this product does not increase the effectiveness of the product. Block or Log forms of PAM and PAM blends are manufactured for specific use in drainage waterways to remove suspended particulates from runoff.

According to Green and Scott (2001), PAM is versatile and effective in reducing runoff, erosion and soil sealing. It is also economical compared to other methods such as straw mulch product.

2. When to Use

PAM is suitable for use on disturbed soil areas that discharge to a sediment trap or sediment basin. PAM is typically used in conjunction with other BMPs to increase their performance.

According to California Stormwater BMP Handbook (2003), PAM can be applied to the following areas:

- a. Rough graded soils that will be inactive for a period of time
- b. Final graded soils before application of final stabilization (eg. paving, planting, mulching)
- c. Temporary haul roads prior to placement of crushed rock surfacing
- d. Compacted soil road base
- e. Construction staging, materials storage, and layout areas
- f. Soil stockpiles
- g. Areas that will be mulched

3. How to Apply

Prior to the start of construction, the application area or flow rate must be identified and the selection of a polymer made. Any polymer or alum must meet toxicity tests. If spreading of a polymer is used, applications assume that uniform coverage is attained. The application should conform to the design and specifications provided in the plans.

Site Preparation

Prepare site following the project design and specifications.

PAM Application - Criteria for Land applied PAM Specifications

PAM shall be mixed and/or applied in accordance with all Occupational Safety and Health Administration (OSHA) Material Safety Data Sheet (MSDS) requirements and the manufacturer's recommendations for the specified use conforming to all federal, state and local laws, rules and regulations.

4. Type of Polymers

The use of PAM logs or block formulations may be the most effective methods for colloidal clay, nutrient and metal treatment in flowing water due to the ability to add reactive chemicals that will act upon the desired target clay, nutrient or metal. Column studies using site specific PAM formulations for waste rock have shown removal rates of 99% zinc, 99% copper, 99% silver, 54% phosphorous and 71% manganese (Iwinski, Stein, and Condon, 1996). An added benefit of these formulations is the ability of the molecules to utilize lignin or chelate reaction with metals, nutrient and clays which further reduce solubility and enhance more rapid settling characteristics (Yoon, et al., 1994). Liquid injection and powder feeding systems are either quite costly or lack the ability to carry the required treatment additives significantly reducing their performance and requiring expensive filtration to remove chemical residues and fine contaminants.

Specific blended PAM logs or blocks may be constructed in various ways to allow varying degrees of dosage application. This allows for multiple passive types of applications and a large degree of versatility for construction sites, runoff water and metal contaminated water flows. The absence of toxicity of these materials to aquatic organisms (Applied Polymer Systems, 2003) has created a much more versatile application window allowing for direct discharge to riparian waterways and substantially reducing cost. Particulate that is formed from these types of applications may be captured onto organic fabric surfaces or settled using conventional ponds, baffle grids or constructed wetlands. (McLaughlin, Hayes, and Bartholomew, 2003) Pipe mixing systems have the ability to react the turbid water with the polymer mixes rather quickly and settling times of particulates once reacted with the blended PAM logs or blocks are greatly reduced. This feature can allow for much smaller pond sizes, which reduce the area footprint of the pond and overall cost. This has prompted engineers to utilize this concept into project designs where a conventional pond may not be used, due to available land size restrictions, or in cases where water quality issues may arise. This new capability has allowed higher density development and land use, which only a few years ago were not, considered due to high construction costs or environmental risk.

5. Choice of Polymers

The term 'Polymer Clarifier' refers to a polyacrylamide (PAM) and PAM blend, inclusive of any additives, i.e., a whole product as delivered by a manufacturer rather than an ingredient within a product delivered by a manufacturer. Only Polymer Clarifiers meeting all of the following criteria may be used:

- a. The Polymer Clarifier must be anionic (negatively charged).
- b. Specifically, no cationic formulations of a Polymer Clarifier will be accepted. Cationic forms of PAM, polymers and chitosan have high levels of toxicity to aquatic organisms. Emulsions shall never be applied directly to runoff or riparian waters due to surfactant toxicity.
- c. The PAM or PAM blend must be certified for compliance with ANSI/NSF Standard 60, potable drinking water grade, indicating a maximum residual acrylamide monomer limit of 0.05%.
- d. The manufacturer must provide a toxicological report for the Polymer Clarifier, performed by a third-party, approved laboratory. The information within the report must be derived from whole-product testing, using one or all of the protocols listed below, as designated by the species selected by the appropriate regulatory authority. The report shall verify that the Polymer Clarifier

exhibits acceptable toxicity parameters set by all applicable standards:

- i. EPA-821-R-02-012 (acute testing);
 - ii. EPA-821-R-02-013 (chronic testing);
- e. The manufacturer must provide a test report indicating that the Polymer Clarifier, when tested with site-specific soils, demonstrates a lab performance level of at least 95% in reducing NTU or TSS levels. In Florida, the post-treated value of NTU must be less than 29.

6. Dosage Calculations

- a) The dosage rates are described with each of the applications in Section 13 and are based on Florida soils. Polymer dosage rates will vary with site-specific applications along with water and soil requirements. Higher doses of certain polymer types or blends may result in extreme viscosity and may result in impaired applications when using spraying devices. The polymer enhancements within this document are systems or methods that have been used over five or more years across the United States and Canada. All of the contained BMPs are in use in Florida and have performed as described when installed correctly. The entire polymer enhanced BMPs within this document are actual excerpts from applications within the southeastern United States. Each of the contained BMPs or their combinations have been documented and monitored. Reported water quality data, university testing documentation or NPDES reported data was used to verify the effectiveness of these BMPs.
- b) Polymer logs that are assembled from multiple polyacrylamide polymers, stabilizers and dispersion chemicals will absorb water and swell by varying values in relation to water chemistry, temperature, flow rate and time of reaction. This condition prohibits or greatly restricts the ability to mass balance the dissolution rate of the polymer log for dosage calculation. To accurately ascertain the dosage rate of each log type a controlled flow device was assembled, as shown in Figure 1, where the only variable is solubility. A piped system was constructed using filtered water (5 micron), which created a sustained flow rate and allowed for swelling of the polymer log without flow variation. This allowed for periodic sampling in which TSS and TDS could be analyzed. A standard was taken and the test samples were obtained at 5-minute intervals with five samples each for the three different polymer log types.



Figure AIII-1: Polymer Log dosage sampling device.

Each of the three polymer log types was constructed to a standard mold so the surface area would be the same and used as a reference size for the dosage calculation. The calculations of surface area are shown in Table 1.

Table 1: Surface Area Calculations of Polymer Log

Measured Parameters: 29 inches long with 2-inch diameter

Total surface area of log:

$$SA_{\text{total}} = SA_{\text{ends}} + SA_{\text{face}} \cdot SA_{\text{total}} = 2\pi r^2 + 2\pi rh$$

$$SA_{\text{total}} = 2 \times (3.14) \times (1 \text{ inch})^2 + 2 \times (3.14) \times (1 \text{ inch}) \times (29 \text{ inch})$$

$$SA_{\text{total}} = (6.28 \text{ in}^2) + (182.12 \text{ in}^2) = SA_{\text{total}} = \mathbf{188.40 \text{ inches}^2}$$

The flow rate was recorded throughout the sampling to assure no variation of flow and the flow rates for each of the three logs then calculated, as shown in Table 2. An outside certified lab then performed the TSS and TDS analysis and this data was used to calculate the actual dosage of each polymer log type as listed in Table 3.

Table 2: Flow Rate calculations for each Polymer Log**703d Polymer Log**

Filled 5 gallon pail in

46.82 seconds, 45.78 seconds, 45.62 seconds

Average = 46.07 seconds

$$\frac{5}{46.07 \text{ sec}} \times \frac{60 \text{ seconds}}{1 \text{ minute}} = 6.51 \text{ gallons per minute (gpm)}$$

703d#3 Polymer Log

Filled 5 gallon pail in

45.62 seconds, 45.09 seconds, 44.92 seconds

Average = 45.21 seconds

$$\frac{5}{45.21 \text{ sec}} \times \frac{60 \text{ seconds}}{1 \text{ minute}} = 6.63 \text{ gallons per minute (gpm)}$$

706b Polymer Log

Filled 5 gallon pail in

46.07 seconds, 45.20 seconds, 45.33 seconds

Average = 45.53 seconds

$$\frac{5}{45.53 \text{ sec}} \times \frac{60 \text{ seconds}}{1 \text{ minute}} = 6.59 \text{ gallons per minute (gpm)}$$

Table 3: Dosage Rate calculations

	TDS	TSS		TDS	TSS
Control	33	BRL			
703d #1	32	BRL	Average:	45.2	BRL
703d #2	48	BRL			
703d #3	51	BRL	Total Average:	45.2	mg/L
703d #4	41	BRL	minus control:	12.2	mg/L
703d #5	54	BRL			
703d#3 #1	55	6	Average:	47.0	6.8
703d#3 #2	46	7			
703d#3 #3	38	8	Total Average:	53.8	mg/L
703d#3 #4	60	6	minus control:	20.8	mg/L
703d#3 #5	36	BRL			
706b #1	75	BRL	Average:	57.4	BRL
706b #2	57	BRL			
706b #3	55	BRL	Total Average:	57.4	mg/L
706b #4	45	BRL	minus control:	24.4	mg/L
706b #5	55	BRL			

7. Performance Based Index Testing (NTU)

All vendors and suppliers of PAM, PAM mix or blends shall supply written “site specific” testing results demonstrating a performance of 95% or greater reduction of *NTU* or *TSS* from runoff waters. Emulsion batches shall be mixed following recommendations of a testing laboratory that determines the proper product and rate to meet site requirements. Application method shall insure uniform coverage to the target area. **(Emulsions shall never be applied directly to runoff or riparian waters)**

Dry form (powder) may be applied by hand spreader or a mechanical spreader. Mixing with dry silica sand will aid in spreading. Pre-mixing of dry form PAM into fertilizer, seed or other soil amendments is allowed when specified in the design plan. Application method shall insure uniform coverage to the target area. Block or Log forms shall be applied following site testing results to assure proper placement and performance and shall meet or exceed state and federal water quality requirements.

Example Field Project – Example of a Flow-through System

A local development project needing assistance for dewatering supplied the test ponds both having elevated *NTU* values due to colloidal clay content. A complete dewatering system was set up as shown in Figures 2 and 3, using the pipe mixer feeding to a jute lined ditch to collect the particulate from the mixer. *NTU* readings were taken in each pond before pumping and recorded as background. Samples were taken every 5 minutes from end of mixer and the end of jute field before discharge to the riparian stream; the data is presented in Table 4. The pond volumes treated were calculated using the pump flow per time from start to finish. Two pipe mixing systems were used connected in a series using a duplex system. The duplex system for this water chemistry required the first mixer to be loaded with 8 each 703d polymer logs and the second mixer to be filled with 706b polymer logs. Using the dosage value derived from the lab test based on surface area of the polymer log the dosage was then adjusted to the surface area of the polymer logs within the mixers. Using the dosage rates measured in the lab the total dosage for the system was estimated to be 217.6 mg/L



Figure AIII-2: The water was pumped out of the sediment pond.



Figure AIII-3: The water was pumped through the pipe mixers and down a jute lined ditch.

Table AIII-4: APS Pipe Mixer Field Test 4/6/06

Site: Holly Commons		Soil Type: Silty Clay		Date: 4/6/06			
Background: 400 NTU, 5.38 pH		Flow Rate: 133 GPM		Conditions: Clear, sunny			
	End of Mixer filtered with coffee filter				End of Jute Field		
	Time	NTU	pH	NTU	pH	NTU	pH
Initial	10:25	35	5.8	24	5.84		
5 min	10:30	22	5.42	19	5.45	17	5.47
10 min	10:35	25	5.5	17	5.55	18	5.48
15 min	10:40	24	5.66	17	5.58	19	5.6
20 min	10:45	24	5.63	16	5.66	16	5.63
25 min	10:50	23	5.65	16	5.65	19	5.63
30 min	10:55	23	5.63	14	5.66	20	5.67
35 min	11:00	22	5.73	15	5.7	19	5.72
40 min	11:05	23	5.7	13	5.75	19	5.76
45 min	11:10	24	5.72	14	5.75	21	5.74
50 min	11:15	25	5.73	14	5.74	17	5.73
55 min	11:20	25	5.72	14	5.75	18	5.76
1 hour	11:25	40	5.73	13	5.73	32	5.74
1h 5 min	11:30	31	5.75	14	5.71	16	5.71
1h 10 min	11:35	25	5.77	16	5.75	20	5.74
1h 15 min	11:40	23	5.79	15	5.75	20	5.78
1h 20 min	11:45	25	5.76	15	5.74	19	5.76
1h 25 min	11:50	24	5.74	16	5.75	19	5.77
1h 30 min	11:55	27	5.76	14	5.73	23	5.74
1h 35 min	12:00	25	5.84	15	5.8	20	5.83
1h 40 min	12:05	23	5.81	13	5.76	19	5.79
1h 45 min	12:10	22	5.8	14	5.78	18	5.81

8. Toxic Requirements and Index Testing

All vendors and suppliers of PAM, PAM mix or blends shall present or supply a written toxicity report which verifies that the PAM, PAM mix or blend exhibits acceptable toxicity parameters which meet or exceed the requirements for the state and federal water quality standards.

Cationic forms of PAM are not allowed for use under this guideline due to their high levels of toxicity to aquatic organisms. Emulsions shall never be applied directly to runoff or riparian waters due to surfactant toxicity.

Toxicological tests for the PAM is to be conducted using one or all of the protocols listed below, as designated by the species selected by the appropriate regulatory authority. The report shall verify that the Polymer Clarifier exhibits acceptable toxicity parameters set by all applicable standards:

EPA-821-R-02-012 (acute testing for freshwater/marine organisms);

EPA-821-R02-013 (chronic testing for freshwater organisms);

9. Design Considerations

A discussion of design considerations is included with each application of polymers and alum.

10. Limitations of Use

Consult with a registered design professional for assistance if any of the following occur:

- Problems with application equipment clogging.
- PAM alone may not meet testing requirements for NTU reduction and soil stabilization. Site specific “blends” may be needed to meet these requirements.
- Application specifications for PAM cannot be met; alternatives may be required. Unapproved application techniques could lead to failure.
- Visible erosion occurs after application.

11. Inspection and Maintenance Requirements

An operation and maintenance plan must be prepared for use by the operator responsible for PAM application. Plan items should include the following items.

- Reapply PAM to disturbed or tilled areas that require continued erosion control.
- Maintain equipment to provide uniform application rates.
- Rinse all PAM mixing and application equipment thoroughly with water to avoid formation of PAM residues and discharge rinse water to soil areas where PAM stabilization may be helpful.
- Downstream deposition from the use of PAM may require periodic sediment removal to maintain normal functions.

The California Stormwater BMP Handbook (2003) suggests the following steps for an effective inspection and maintenance plan:

- Inspect BMPs prior to forecast rain, daily during extended rain events, after rain events, weekly during the rainy season, and at two-week intervals during the non-rainy season.
- Areas where erosion is evident should be repaired and BMPs re-applied as soon as possible. Care should be exercised to minimize the damage to protected areas while making repairs, as any area damaged will require re-application of BMPs.
- PAM must be reapplied on actively worked areas before storm events or when disturbance ceases if

PAM is to remain effective.

- Reapplication is not required unless PAM treated soil is disturbed or unless turbidity levels show the need for an additional application.
- If PAM treated soil is left undisturbed a reapplication may be necessary after two months.
- More PAM applications may be required for steep slopes, silty and clayey soils (USDA Classification Type “C” and “D” soils), long grades, and high precipitation areas.
- When PAM is applied first to bare soil and then covered with straw, a reapplication may not be necessary for several months.
- Discharges from PAM treated areas must be monitored for non-visible pollutants.

12. Applications

Polymer Enhanced Soil Stabilization

To stabilize the soil on any slope conditions to prevent erosion. Polymer additions can assist temporary or permanent grassing by binding the seed, fertilizer, mulch, and soil together until the grass germinates.

a) *Hydroseeding*

A soil-specific polymer can be added into the hydroseeding mix and applied over slopes. It has been tested when mixed with blended fiber matrix (BFM). The polymer reacts with the soil, binding the mulch, seed, fertilizer, and other additives to the soil, holding it together until vegetation is established. Matting can be applied over the top of the hydroseeded areas, especially in areas with steep slopes, to ensure that the hydroseed mix is not washed away should heavy runoff occur. The polymer combines soil chemistry and emulsion theory. This is the basis for BFM in that PAM increases tackifier characteristics and enhances the wood-based mulch.

- i. Application rate: varies by soil content and grade of slope.
 - Gentle to Moderate slopes (flat to 1V:4H)
 - High Clay Content: 10-20 # powder or 1.5-2.0 gallons emulsion
 - High Sand Content: 15-20 # powder or 1.5-2.0 gallons emulsion
 - Steep slopes (1V:3H to 1V:1H)
 - High Clay Content: 20-35 # powder or 1.5-2.5 gallons emulsion
 - High Sand Content: 25-50 # powder or 2.0-2.5 gallons emulsion
- ii. Polymer emulsion or powder shall be added to all hydroseeding mixes at the above application rates per 3000 gallons of water, and then applied at the rate of 3000 gallons of hydroseed mix/ acre (**NOTE: Emulsion and powder additions are limited by high viscosity, at the higher limits listed above.** Site testing will determine the correct polymer type.)
- iii. Polymer shall be added slowly as the final additive to the hydroseeding mix. Addition en-masse will cause clumping of the polymer and may cause clogging of the spraying equipment.
- iv. Due to the viscous nature of the polymers, the hydroseed mix should be applied to the soil as soon as possible after polymer has been added.
- v. Straw, mulch, matting, or jute cover may be applied over the hydroseeded application.

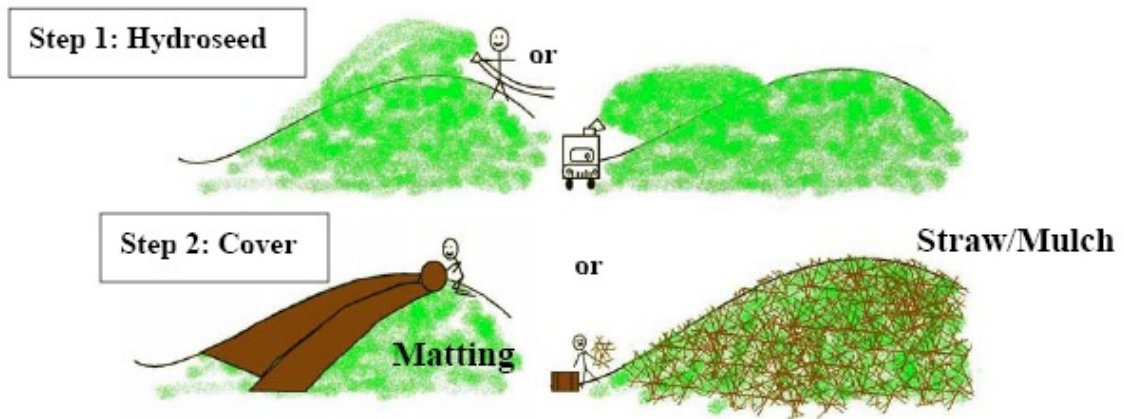

Limitations: Soil Samples must be tested for effectiveness so that a performance based criteria is implemented. Other limitations include slope steepness, type of clay (solubility, swelling characteristics, etc.)

Figure AIII-4: Hydroseeding Application.

b) *Direct Soil Application Using a Granular Powder*

A soil-specific polymer can be applied directly to the soil surface, using a seed/fertilizer spreader, either alone or as part of a mix. The polymer reacts with the soil, binding the mulch, seed, fertilizer, and other additives to the soil, holding it together until vegetation is established. Matting can be applied over the top of these areas, especially in areas with steep slopes, to ensure that the mix is not washed away should heavy runoff occur.

- i. Application rate: varies by soil content and grade of slope.
 - Gentle to Moderate slopes (flat to 1V:4H)
 - High Clay Content: 10-20 # powder
 - High Sand Content: 15-20 # powder
 - Steep slopes (1V:3H to 1V:1H)
 - High Clay Content: 20-35 # powder
 - High Sand Content: 25-50 # powder
- ii. Dry soil-specific polymer powder shall be applied using a seed or fertilizer spreader alone or may be mixed with other dry spread additives.
- iii. Straw, mulch, matting, or jute cover should be applied over the soil-specific polymer application.

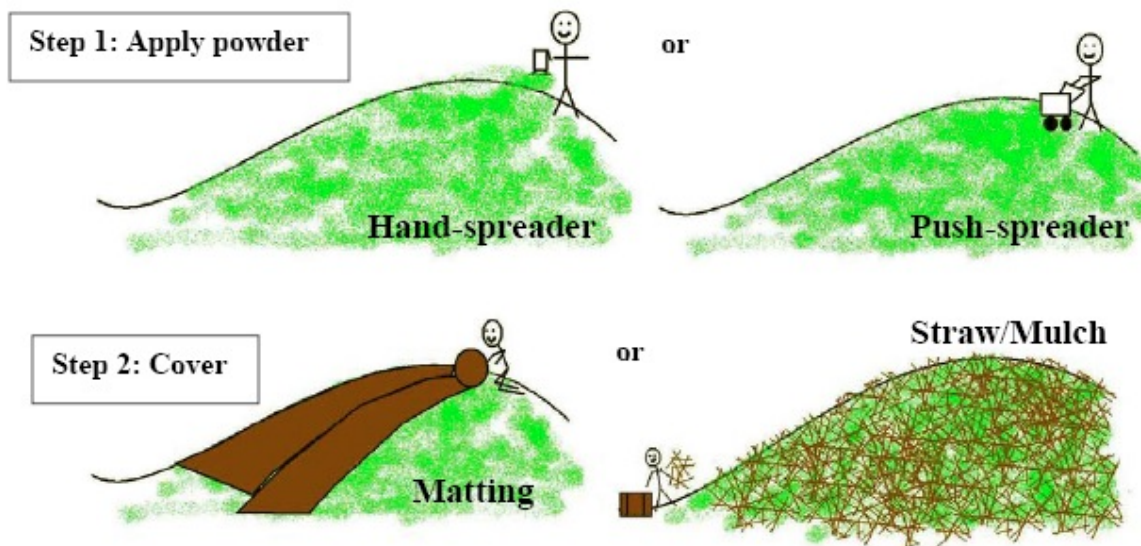

Limitations: Soil Samples must be tested for effectiveness so that a performance based criteria is implemented. Other limitations include slope steepness, type of clay (solubility, swelling characteristics, etc.)

Figure AIII-5: Granular powder direct soil application.

c) *Polymer Enhanced Armoring with Matting*

Polymer Enhanced Armoring is the process by which soft pliable matting such as jute, coir, coconut, hemp or burlap is placed onto the soil surface. A soil-specific polymer is then applied which reacts with the metals and clays within the soil to bind it together. This complex attaches to the matting creating a highly erosion-resistant surface that will support vegetation along with aiding in the attachment of fine particulate to the matting surface.

- i. For soil stabilization; can be used in conjunction with Channel Stabilization, Stream Crossings, Permanent Soil Reinforcing Matting, and Surface Roughening.
- ii. Application rate: varies by soil content and grade of slope.
 - Gentle to Moderate slopes (flat to 1V:4H)
 - High Clay Content: 10-20 # powder
 - High Sand Content: 15-20 # powder
 - Steep slopes (1V:3H to 1V:1H)
 - High Clay Content: 20-35 # powder
 - High Sand Content: 25-50 # powder
- iii. One or more layers of jute or other matting shall be applied to the surface of all exposed soil on 2:1 slopes or greater.
- iv. The matting must have ½” – 1” open area to allow for polymer, seed, and fertilizer to fall through the matting. If tighter weaved matting is used, apply the soil-specific polymer powder first.
- v. Ensure matting is flush to the soil surface to allow soil adherence and prevent erosion due to “tenting.”
- vi. Apply polymer powder on top of matting using a seed or fertilizer spreader or the powder can be mixed with other dry spread additives.



Figure AIII-6: Polymer-enhanced Armoring with Matting.

Apply Matting flush to soil surface:



Application in areas of concentrated flow:



Armoring Application with Hydroseeder over Matting:



d) Polymer Enhanced Turf Reinforced Matting or Cover Matting

Polymer Enhanced erosion control matting can be used on a temporary or non-temporary basis to stabilize the soil by supporting the grass roots and providing long-term protection. A soil-specific polymer can be applied directly to the soil surface, using a seed/fertilizer spreader, either alone or as part of a mix. The polymer reacts with the soil, binding the mulch, seed, fertilizer, and other additives together, which attaches to the matting creating a highly erosion-resistant surface that will help to support the vegetation until it is established. TRMs function as permanent matting but only after vegetation is established. Polymer applications can greatly increase the effectiveness of TRMs and matted surfaces. PAM increases the holding power of the soil and stops the potential for erosion under the TRM.

- i. Application rate: varies by soil content and grade of slope.
 - Gentle to Moderate slopes (flat to 1V:4H)
 - High Clay Content: 10-20 # powder
 - High Sand Content: 15-20 # powder
 - Steep slopes (1V:3H to 1V:1H)
 - High Clay Content: 20-35 # powder
 - High Sand Content: 25-50 # powder
- ii. One layer of jute or other matting shall be applied to the surface of all exposed soil on 2:1 or steeper slopes.
- iii. Apply polymer powder on top of matting using a seed or fertilizer spreader or may be mixed with other dry spread additives.
- iv. Ensure matting is flush to the soil surface to allow soil adherence and prevent erosion due to “tenting.”

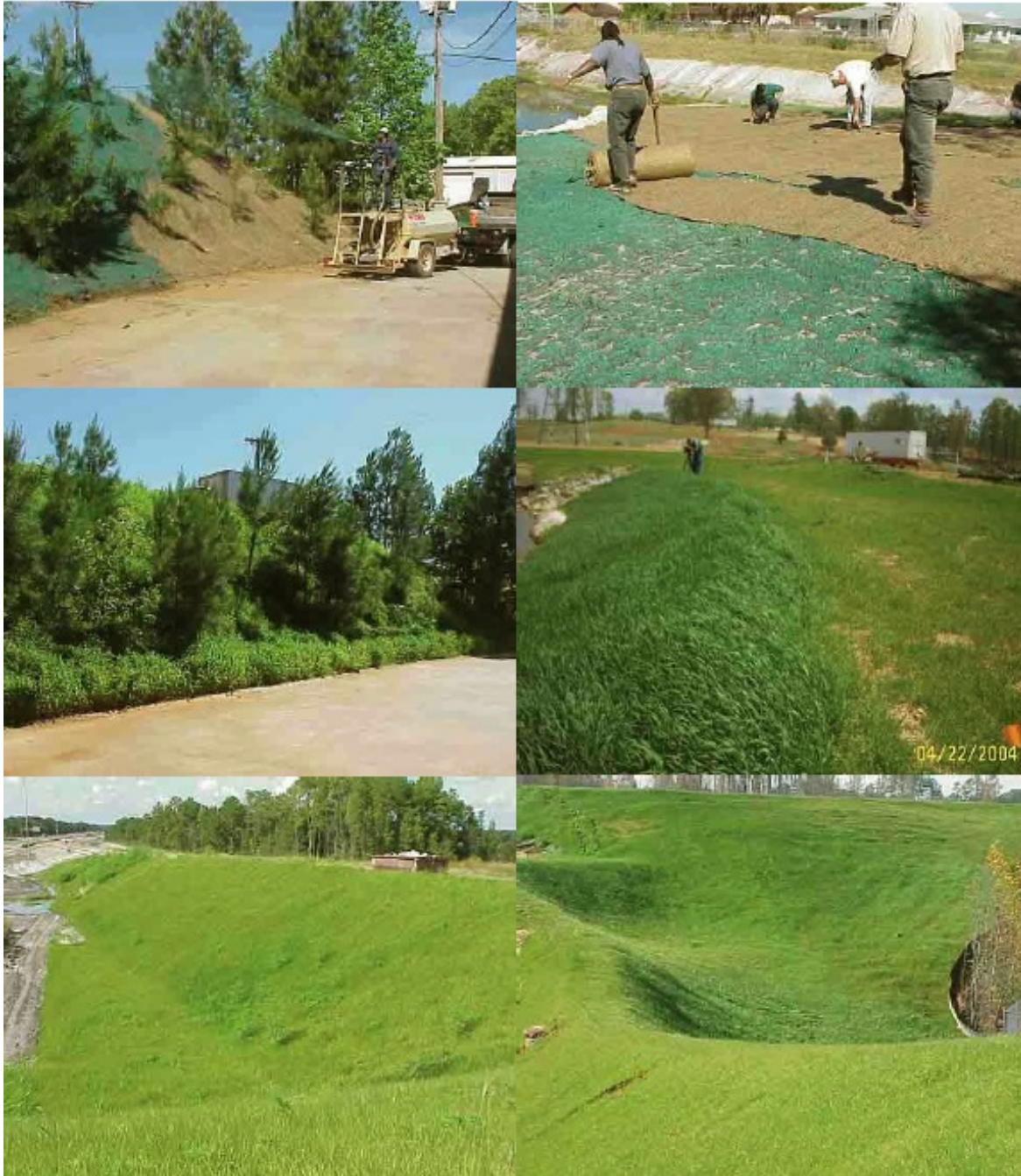

Figure AIII-7: Polymer-enhanced Turf Reinforced Matting.

e) *Polymer Enhanced Earth Berms*

An earthen berm is constructed at the edge of an embankment to prevent slope erosion, direct runoff to a down drain or catchments area, and protect working areas from surface runoff. These can be made more effective and protected from erosion by covering with jute fabric and applying with the correct site-specific polymer. The polymer reacts with the suspended particles in the runoff water, similar to polymer enhanced soft armor, binding and adhering them to the matting, protecting the berm from the erosive forces and greatly improving the water quality as it moves towards a detainment area or site discharge. It may be used in conjunction with ECB at the inside berm toe depending on the anticipated flows.

- i. Temporary earth berms are used to intercept runoff water and reduce slope erosion. These can be made more efficient by covering with jute matting and applying polymer powder.
- ii. One layer of jute or other matting shall be applied to the surface of the diversion, overlapping abutting pieces so that the upstream piece is on top of the downstream piece.
- iii. Apply dry polymer powder to the matting cover, using a seed or fertilizer spreader.
- iv. Application rate: varies by soil content and grade of slope.
 - Gentle to Moderate slopes (flat to 1V:4H)
 - High Clay Content: 10-20 # powder
 - High Sand Content: 15-20 # powder
 - Steep slopes (1V:4H to 1V:1H)
 - High Clay Content: 20-35 # powder
 - High Sand Content: 25-50 # powder



Limitations: Soil Samples must be tested for effectiveness so that a performance based criteria is implemented. Other limitations include slope steepness, type of clay (solubility, swelling characteristics, etc.)

Figure AIII-8: Polymer-enhanced Earth Berms.

f) *Polymer Enhanced Channel Stabilization*

Erosion occurs along areas of concentrated flow, causing rills to develop and channels to widen. To protect the channel bed, it is Soft Armored, and covered with soft pliable open-weave matting such as jute. A soil-specific polymer is used to stabilize a channel either with constant or intermittent flow, binding the soil to prevent erosion. Plastic sheeting may need to be laid down beneath the matting when used as a water quality device, especially if the channel is in highly erosive or contains sandy soils.

- i. Application rate: varies by soil content and grade of slope.
 - Gentle to Moderate slopes (flat to 1V:4H)
 - High Clay Content: 10-20 # powder
 - High Sand Content: 15-20 # powder
 - Steep slopes (1V:3H to 1V:1H)
 - High Clay Content: 20-35 # powder
 - High Sand Content: 25-50 # powder
- ii. One or more layers of jute or other matting shall be applied to the surface of the channel, overlapping abutting pieces so that the upstream piece is on top of the downstream piece.
- iii. Apply polymer powder on top of matting using a seed or fertilizer spreader or may be mixed with other dry spread additives.

PAM will not replace the need to assess the shear stress and velocity limitations of TRM. It can reduce the erosion potential.

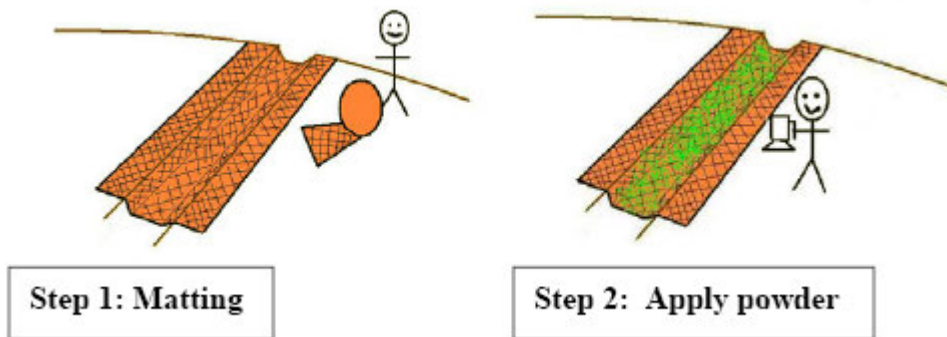

Limitations: Soil Samples must be tested for effectiveness so that a performance based criteria is implemented. Other limitations include slope steepness, type of clay (solubility, swelling characteristics, etc.)

Figure AIII-9: Polymer-enhanced Channel Stabilization.

g) Stream Crossing and Culvert Stabilization

A stream crossing is a bridge or pipe structure protecting a watercourse used when a roadway crosses over a stream or waterway to prevent damage from construction equipment. The slope from the roadway down to the streambed can be protected from erosion by applying polymer enhanced Soft Armoring. Soft pliable open-weave matting is laid along the slopes on either side of the roadway, and is then applied with the correct soil-specific polymer. The polymer reacts with the metals and clays within the soil to bind it together, which attaches to the matting creating a highly erosion-resistant surface and prevents erosion around the structure.

- i. Application rate: varies by soil content and grade of slope.
 - Gentle to Moderate slopes (flat to 1V:4H)
 - High Clay Content: 10-20 # powder
 - High Sand Content: 15-20 # powder
 - Steep slopes (1V:3H to 1V:1H)
 - High Clay Content: 20-35 # powder
 - High Sand Content: 25-50 # powder
- ii. One or more layers of jute or other matting shall be applied to the soil surface surrounding the stream crossing, where erosion would be present.
- iii. Apply polymer powder on top of the matting using a seed or fertilizer spreader or may be mixed with other dry spread additives.



Figure AIII-10: Stream Crossing or Culvert Stabilization.

Polymer Enhanced Runoff Treatment

What is its purpose?

To protect drainage channel against erosion due to flowing water.

Where and how is it commonly used?

- In drainage channels where vegetation needs to be established and significant flows occur

When should it be installed?

- While construction activities are occurring.
- After construction activities are finished.

When should it not be installed?

- Over impervious surfaces.
- On very rough ground.

What needs to be inspected?

- Does the RECP display any damage?
- Was the channel bed smooth when the RECP was installed?
- Have check structures (staple or trench) been installed?
- Is water flowing under the blanket and causing erosion?
- Are sufficient numbers of staples used?
- Is the correct material used?
- Was seed applied?
- Should hay/straw mulch be used?

What maintenance activities can be expected?

- Repair and replacement of material.
- Repair of eroded ground.

NOTES

Erosion Control Blankets (ECBs) are composed of natural material including straw, straw-coconut, coconut (or coir), wood excelsior, and so forth. They should be held in place with netting sewn on both sides of the material.

One type of Turf Reinforcement Mats (TRMs) is composed of 100% polypropylene or nylon and held in place with netting sewn on both sides of the material.

Another type of TRM is composed of straw-coconut or coconut matter reinforced with strands of polypropylene threads and all held in place with netting sewn on both sides of the material.

Designers must complete shear stress and velocity calculations in selecting an ECB or TRM for drainage channels.

Additional information about ECBs and TRMs can be found at www.ectc.org.

Jute materials are effective, biodegradable and low cost. They are a commonly used BMP in Florida.

Polymer Enhanced Stormwater Treatment

Site-specific polymers can be used to clarify runoff, removing sediment and reducing the total suspended solids.

1. Polymer Enhancement for Erosion Control & Water Quality

a) Drop Inlet Barriers

A sediment trap used to prevent silt from entering the pipe system. The sediment is trapped outside of the barrier, clarifying the water as it enters the inlet.

b) Silt Fence, Square

A wood frame covered with silt fence or filter fabric is constructed to encircle the drop inlet and protect the inlet from being filled with sediment. Soil-specific polymer is applied to the soil surrounding the inlet and then covered with a layer of jute fabric. The Polymer Enhanced Armoring application will reduce water undercutting the drop inlet device. As the turbid runoff water passes across the jute matting with site-specific polymer, it reacts with the site-specific polymer clarifying the water and dropping out the suspended particles.

- i. Install silt fence or filter fabric to enclose the drop inlet. Space support posts evenly, to a maximum of 3 feet apart. Drive the posts 1.5 feet into compacted fill around the inlet.
- ii. The silt fence or filter fabric should be designed to allow at least 70 GPM/ft² of water to pass through it. FDOT approved silt fence or equivalent.
- iii. Wire backed silt fence can be used if additional support is needed.
- iv. Cross brace in corners to prevent collapse.
- v. Apply a layer of jute or other soft pliable matting on the ground around the outside of the inlet barrier.
- vi. Apply the appropriate soil-specific polymer powder over the matting as outlined in the section Polymer Enhanced Armoring with Matting.
- vii. Inspect and repair as needed, remove accumulated sediment after every storm.



Limitations: Inflow values must not exceed outflow values. Suggested outflow value is to be greater than 70 gpm/sq. ft of silt fence areas. This implies that the standard woven or needle punched silt fence materials may not be adequate. A monofilament woven material may suffice for low flows. In addition, proper installation is critical.

Figure AIII-11: Polymer-enhanced erosion control.

c) Silt Fence, Round

A ring of silt fence or filter fabric is constructed to encircle the drop inlet and protect the inlet from being filled with sediment. Further polymer enhancement using an Armoring application as outlined earlier in this section protects the inlet barrier from being undercut and compromised. As the runoff water passes through the layer of silt fence and jute matting applied with polymer it reacts with the site-specific polymer to clarify the water. The ring configuration is used when the sediment load is very high and is likely to collapse a square structure.

- i. Install silt fence or filter fabric to encircle drop inlet. Space the support posts evenly, to a maximum of 3 feet apart. Drive the posts 1.5 feet into compacted fill around the inlet.
- ii. Make sure that the silt fence is as level as possible.
- iii. The silt fence or filter fabric should be designed to allow at least 70 GPM/ft² of water to pass through it. FDOT approved silt fence or equivalent.
- iv. Wire backing can be added to the silt fence to provide additional support.
- v. Apply a layer of jute or other soft pliable matting to the ground around the outside of the inlet barrier.
- vi. Apply the appropriate soil-specific polymer powder over the matting as outlined in the section Polymer Enhanced Armoring with Matting.
- vii. The velocity of the runoff water should be reduced when approaching the drop inlet, to allow for ponding. The field of jute matting applied with the site-specific polymer can prevent undercutting and failure of the inlet barrier.
- viii. Inspect and repair as needed, remove accumulated sediment after every storm.



Figure AIII-12: Polymer-enhanced erosion control around drop inlet.

d) Filter Stone/ Gravel Ring

A ring of filter stone or gravel is used to protect the drop inlet from being filled with sediment. As the runoff water passes over the cover of jute matting applied with the site-specific polymer and through the stone the polymer reacts with the sediment within the runoff, forming large particles that are trapped between the filter stones, which clarifies the water.

- i. Install around drop inlet, the bottom of the barrier must be sunk into the ground to prevent water and sediment from just going under the barrier.
- ii. Lay jute matting and apply with polymer powder over the ground outside the ring and over the top of the filter stone to reduce the erosion and prevent it from being undercut during heavy flow.

- iii. Application rate: 10-20 pounds of polymer powder/ acre but not greater than 25 pounds/ acre.
- iv. The velocity of the runoff water should be reduced when approaching the inlet barrier to allow ponding to occur.
- v. Inspect and repair as needed, remove accumulated sediment after every storm.

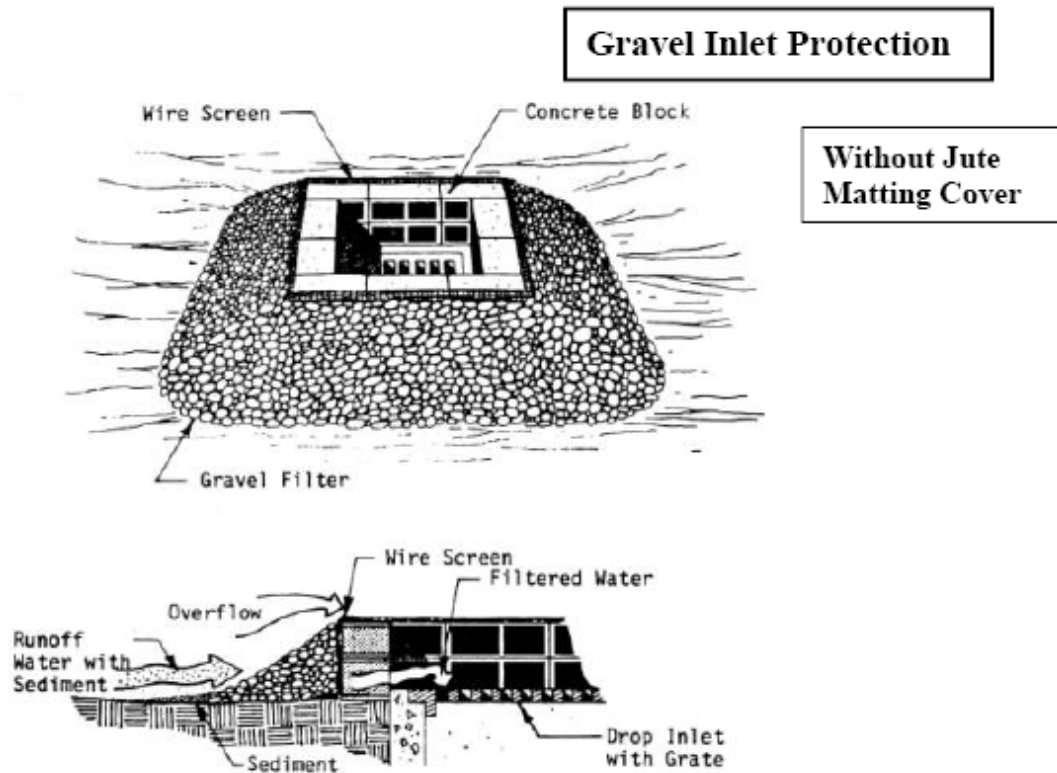

Figure AIII-13: Polymer-enhanced filter stone or gravel ring.

Polymer Enhanced Retrofits

A device or structure placed in front of a permanent stormwater structure to serve as a temporary sediment filter and water removal device. By introducing polymer logs to the turbid water within the permanent stormwater structure up stream, the polymer reacts with the metals and clays within the soil to bind it together, allowing the suspended sediment to be collected using jute or other organic matting downstream. The application of jute matting to the filter stone can greatly enhance capture of particulate and colloidal clay after reaction with the polymer logs.

- i. Install polymer logs inside a retrofit and in upstream water conveyance devices, to treat the water after it has moved through the filter stone.
- ii. Place the polymer logs so that the water flows over and around them. The number of logs is determined by the flow rate of the water. Longer mixing times will have the best reduction of turbidity.
- iii. Check dams or filters need to be installed upstream of the polymer logs to ensure that they are not overwhelmed with sediment.
- iv. Jute or other organic matting must be used downstream of the polymer logs to collect the particulate that is formed. Apply the correct polymer to the jute matting for water quality as

shown below.

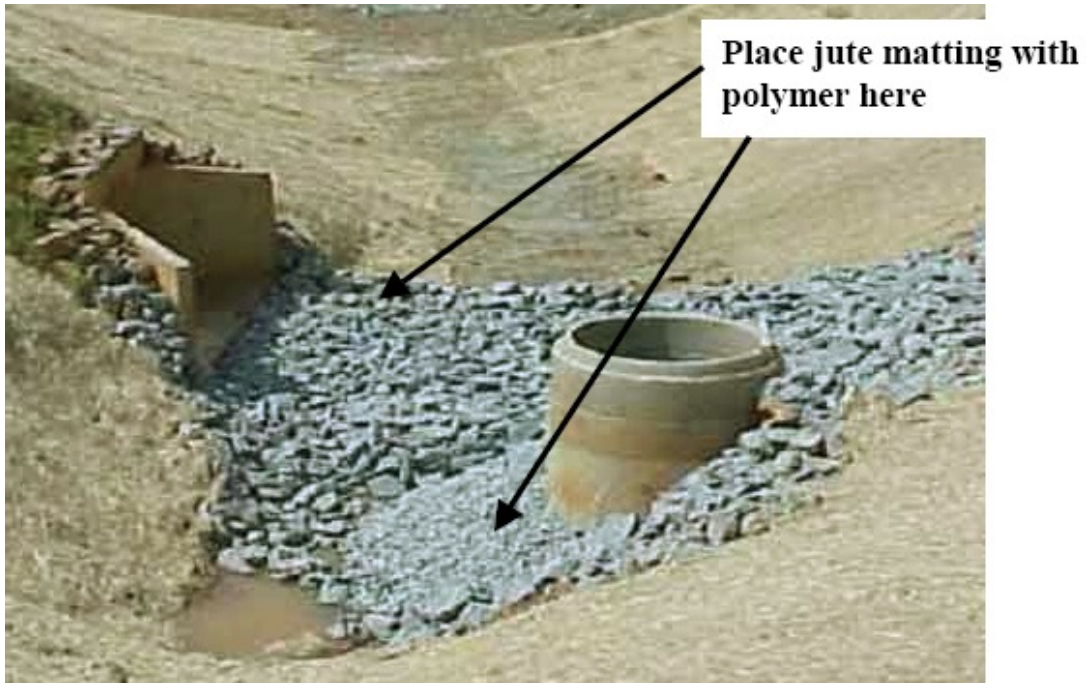

Limitations: It will only work well when the rock anchors the matting. Unless is maintained, the treated water flow through the jute matting may cause blockage of the rock barrier around the riser pipe.

Figure AIII-14: Polymer-enhanced retrofits.

Outlet Protection

A pipe or box culvert outlet headwall with an apron and dissipater blocks used to prevent erosion and slow water. It is used in conjunction with site-specific polymer logs secured upstream of the outlet within the stormwater system. The outlet is enhanced through the use of polymers by laying down jute matting over the dissipater rocks and applying with a soil-specific polymer powder. The reacted sediment attaches to the matting creating a highly erosion-resistant surface along with producing a surface area that aids in attaching fine particulate resulting in increased water quality.

- i. Secure the appropriate site-specific polymer logs in the stormwater system far enough above the outlet to allow for adequate mixing to occur.
- ii. Cover exposed soil and riprap around the outlet with a layer of jute matting to allow particle adhesion of flocculated material and prevent erosion of exposed soil below riprap if heavy flow occurs.
- iii. Apply polymer powder on top of matting using a seed or fertilizer spreader or may be mixed with other dry spread additives.
- iv. Application rate: 15-20 pounds of polymer powder/ acre but not greater than 25 pounds/ acre.

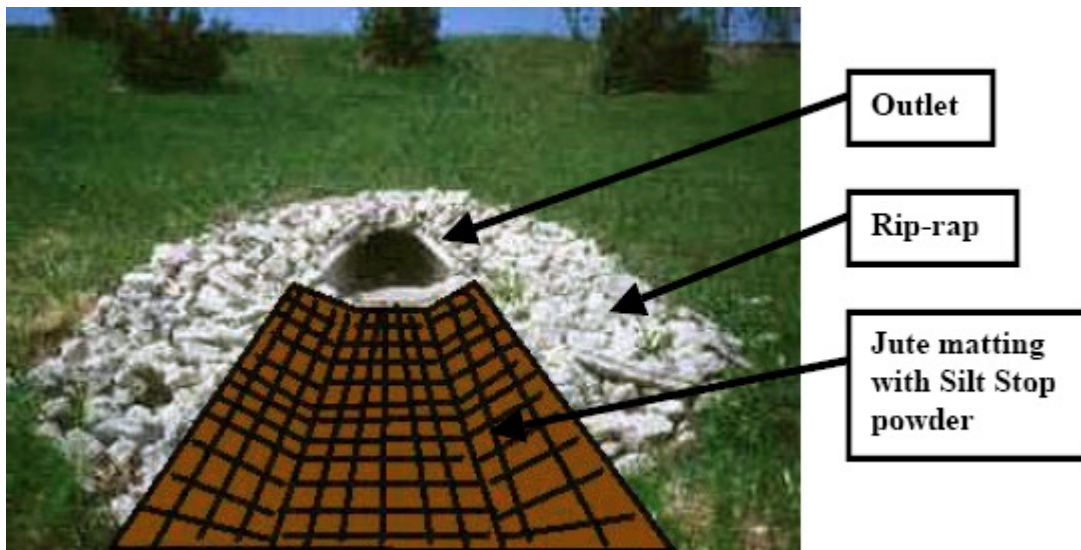

Limitations: If riprap is being placed under the jute, there may be damage to the material for significant flows. It is for this reason that assessing the shear stress and velocity needs to be completed as does placing rock anchors on top of the material.

Figure AIII-15: Polymer-enhanced Outlet Protection.

Polymer Log Enhanced Down Drains

A temporary or permanent pipe used to convey runoff safely down a slope. By introducing polymer logs to the turbid water within the permanent stormwater structure, the polymer reacts with the metals and clays within the soil to bind them together. A layer of jute matting is laid at the outlet at the bottom of the slope and applied with a soil-specific polymer powder. The reacted sediment attaches to the matting creating a highly erosion-resistant surface and clarifying the runoff water.

- i. Cover exposed soil around the top of the down drain pipe with jute or other matting to prevent erosion.
- ii. Apply polymer powder on top of matting using a seed or fertilizer spreader or may be mixed with other dry spread additives.
- iii. Application rate: 15-20 pounds of polymer powder/ acre but not greater than 25 pounds/ acre.
- iv. Polymer logs can be placed in the down drain at the top of the slope, if the runoff water is extremely turbid. (Do not impede flow of water entering down drain.)
- v. At the bottom of the down drain, create a dispersion field by laying jute matting applied with polymer powder, allowing the water to spread out and slow its velocity before hitting the silt fence.
- vi. The silt fence should be designed to allow at least 70 GPM/ft² of water to pass through it. FDOT approved silt fence or equivalent.

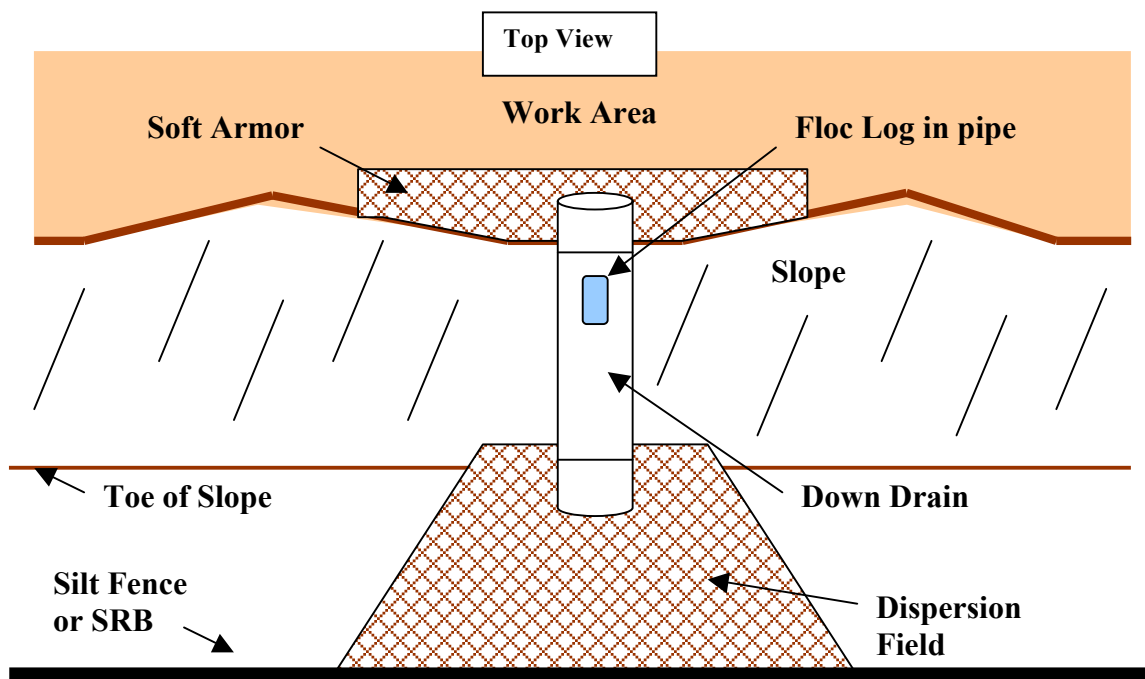

Limitations: High flow velocities will occur at the discharge end of the slope drain. Unless there is a great distance between the slope drain discharge end and the silt fence, and a pond is created, the silt fence barrier may be destroyed if the inflow values are greater than outflow.

Figure AIII-15: Polymer Log Enhanced Down Drains.

Polymer Enhanced Check Dams

Check Dams are used to reduce flow velocity in areas of concentrated flow to reduce the erosive capabilities of the water and allow suspended sediment to settle out. It should not be used in flowing streams.

a) Rock check dams

A check dam constructed of rocks, covered in jute fabric and applied with a site-specific polymer powder. The addition of jute or similar matting and the application of the soil-specific polymer powder can increase particle collection capabilities of the check system. The polymer reacts with the suspended particles, binding them together and adhering them to the matting.

- i. Cover with a layer of jute or coconut matting, secure with some spare rocks.
- ii. Apply dry polymer powder to the matting cover, using a seed or fertilizer spreader. Application rate: 10-20 pounds of powder/ acre but not greater than 25 pounds/ acre.
- iii. If using in conjunction with polymer logs, place the logs on the downstream side of the rock checks, securing with rebar or wooden stakes.

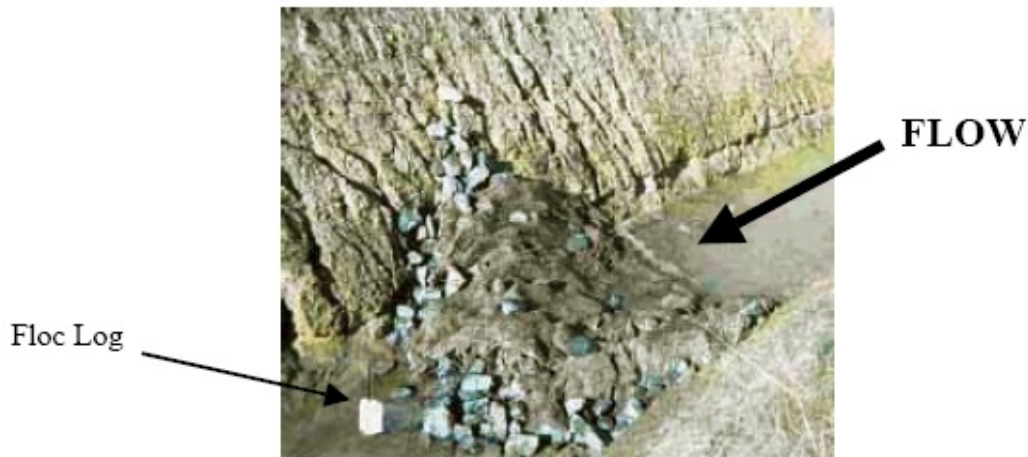

Figure AIII-16: Polymer-enhanced Check Dams.

2. *Sediment Retention Barriers (SRB)*

A double row of silt fence, standing about 4-6 feet apart, filled with loose mulch, straw, woodchips, or other organic matter mixed or blended with the site-specific polymer. It is used on graded sites to trap the fine sediment and clays that flow through the silt fence barrier. With the use of the site-specific polymer, water clarity can be greatly improved while utilizing the function of the silt fence.

a) *Mass Grading Sites/ Grading Sites*

A double row of silt fence filled with loose mulch treated with the site-specific polymer is used to clarify runoff as it moves off of the site. The polymer within the mulch reacts with the suspended sediment, binding it into large particles that are trapped within the mulch, clarifying the runoff.

- i. Install in areas where runoff will exit a site, keeping the installation as level as possible.
- ii. Place perpendicular to flow.
- iii. Use silt fence designed to allow at least 70 GPM/ft² of water to pass through it. FDOT approved silt fence or equivalent.
- iv. Place 2 rows of silt fence 4-6 ft apart. Place loose straw or mulch 3 ft deep between the silt fences (do not compact).
- v. Dry site-specific polymer powder should be spread evenly throughout the straw or mulch using a hand seed or fertilizer spreader.



Limitations: Inflow values must not exceed outflow values. Suggested outflow value is to be greater than 70 gpm/sq. ft of silt fence areas. This implies that the standard woven or needle punched silt fence materials may not be adequate. A monofilament woven material may suffice for low flows.

Figure AIII-17: Sediment Retention Barriers.

b) Sediment Ponds using SRB Applications

SRB is used to capture sediment and treat the runoff as it moves into SCS. The polymer within the SRB reacts with the suspended sediment, binding it into large particles that are trapped within the SRB aiding in clarifying the runoff.

- i. Install the SRB to surround the inlet ditch as it enters the retention pond.
- ii. Make sure that the silt fence is as level as possible.
- iii. Make the SRB large enough to handle 50% or greater of the design stormwater flow. This will contain most of the sediment and clarify the water that moves through it.
- iv. Further sectioning of the retention pond can be done using SRBs; however the key is to make sure the silt fence is level.
- v. Use silt fence designed to allow at least 70 gpm/ft^2 of water to pass through it. FDOT approved silt fence or equivalent.
- vi. Place 2 rows of silt fence 4-6 *ft* apart. Place straw or mulch 3 *ft* deep between the silt fences (do not compact).
- vii. Dry polymer powder should be spread evenly throughout the straw or mulch using a hand seed or fertilizer spreader.
- viii. The polymer powder used will vary with the type of clay and organic content of the site; have soil and water samples from the site tested for the appropriate polymer.
- ix. All exposed soil around the retention pond must be treated with polymer powder to prevent contamination of clarified waters.

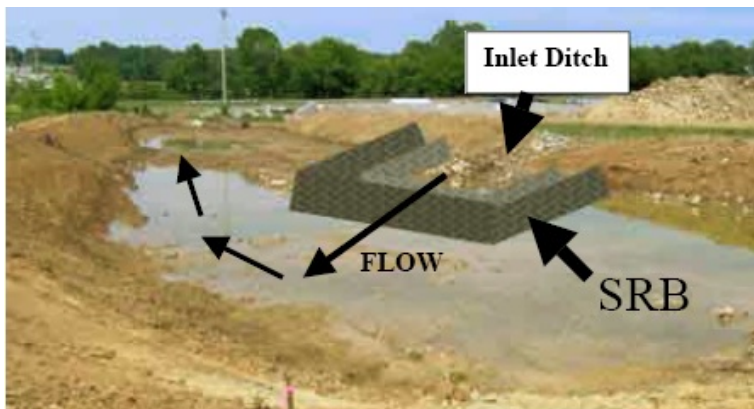

Limitations: Inflow values must not exceed outflow values. Suggested outflow value is to be greater than 70 gpm/sq. ft of silt fence areas. This implies that the standard woven or needle punched silt fence materials may not be adequate. A monofilament woven material may suffice for low flows.

Figure AIII-18: Polymer-enhanced Sediment Ponds using SRBs.

c) Drop Inlets with Polymer Enhancement

A double ring of silt fence or filter fabric is constructed to encircle the drop inlet and filled with mulch or woodchips applied with the site-specific polymer used to protect the inlet from being filled with sediment. As the runoff water passes through the layers of silt fence and mulch applied with polymer it reacts with the site-specific polymer clarifying the water.

- i. Install the silt fence or filter fabric to encircle drop inlet. Space the support posts evenly, to a maximum of 3 feet apart. Drive the posts 1.5 feet into compacted fill around the inlet.
- ii. Make sure that the silt fence is as level as possible.
- iii. Use silt fence designed to allow at least 70 gpm/ft^2 of water to pass through it. FDOT approved silt fence or equivalent.
- iv. Place 2 rows of silt fence 4-6 ft apart. Place straw or mulch 3 ft deep between the silt fences (do not compact).
- v. Dry polymer powder should be spread evenly throughout the straw or mulch using a hand seed or fertilizer spreader.
- vi. Inspect and repair as needed, remove accumulated sediment after every storm.

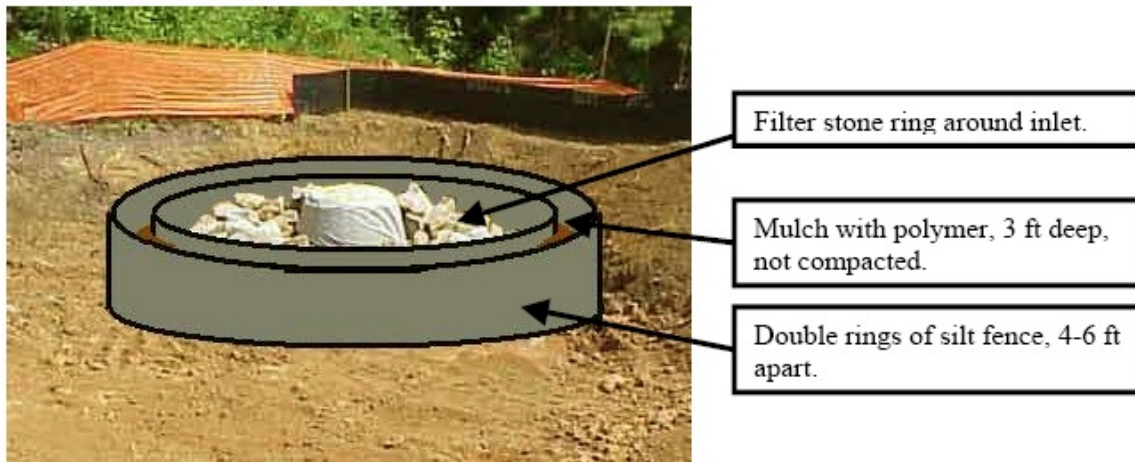

Limitations: Inflow values must not exceed outflow values. Suggested outflow value is to be greater than 70 gpm/sq. ft of silt fence areas. This implies that the standard woven or needle punched silt fence materials may not be adequate. A monofilament woven material may suffice for low flows.

Figure AIII-19: Polymer-enhanced Drop Inlet Protection.

Polymer Enhanced Water Treatment Systems

Polymer Log Mixing Systems

To introduce site-specific polymer logs, to turbid waters in such a manner to facilitate mixing and reaction between the polymer and the suspended particles.

a) Polymer Enhanced Mixing Ditch System

This application is intended for use on temporary or changing sites, where the excavation of a large area or pond is not feasible, and is also used for dewatering operations. A ditch is built up, either by digging out the bed or building up the walls, and can be lined with plastic to prevent erosion if needed. The ditch is lined with jute or similar matting. Checks are placed along the ditch, to increase turbulence and create mixing. Polymer logs are secured along the raceway, allowing the water to mix with the polymer and begin reacting with the suspended sediment.

- i. Open ditch system is an alternative to a pipe or closed drain systems, especially before permanent pipe structures have been installed.
- ii. Cover the exposed soil with jute matting and apply polymer powder to prevent erosion. With highly erosive soils, protection with geotextile or plastic sheeting may be necessary.
- iii. Build checks in the ditch and secure the polymer logs on the downstream side of each check. Make sure that the logs are not resting in mud, drive rebar “feet” into the logs to raise them slightly if needed.
- iv. Logs should be placed in a series. The number of logs is determined by the flow rate of the water and the length of the mixing chamber is determined by the reaction time required for the polymer.
- v. Used in conjunction with a settling pond upstream and usually with a sediment collection system (baffle grids, riprap, settling pond, filter, dispersion field, etc.) downstream.



Limitations: PAM does not replace the need to assess shear stress and velocity limitations of a TRM. However, PAM will reduce the erosion potential and results in better performance. Limitations include slope steepness, type of clay (solubility, swelling characteristics, etc.) Once again, samples must be tested for effectiveness so that a performance-based criteria is implemented.

Figure AIII-20: Polymer Log Mixing Systems.

b) Polymer Log Wire Basket

This system is for use on aquatic sites, when diversion of the water is not feasible, especially for stormwater ditch and drain cleanout projects. A large wire basket is constructed to hold site-specific polymers, allowing water to pass over and around them. The basket with the polymer is placed just downstream of the work site, to allow the turbid water to mix with the polymer and begin to react.

- i. A wire basket is used to introduce polymer into an aquatic site, when diversion of the water is not feasible. Especially for stormwater ditch and drain cleanout projects.
- ii. The wire basket is designed to hold a number of polymer logs and allow water to pass over and around them.
- iii. The basket should be placed closest to the point of turbidity without interfering with the work site; to allow adequate mixing with the polymer as the sediment is introduced into the water column.
- iv. Additional mixing structures may need to be placed in the stream at the same point that the wire basket is located to create turbulence to facilitate appropriate mixing.
- v. The number of polymer logs needed is determined by the flow rate of the water, and distance between the basket and the work site is determined by the reaction time required for the polymer.
- vi. Sediment collection system should be constructed downstream of the work site, to collect the sediment that is flocculated.



Limitations: Monitoring is advisable for water quality concerns.

Figure AIII-21: Polymer Log Wire Basket Systems.

Polymer Enhanced Particle Collection

a) *Dispersion Field*

A delta laid with jute or similar matting treated with site-specific polymer to allow for collection of fine sediment particles from high velocity pumping. The dispersion field is to be used in conjunction with a mixing system and possibly a primary sediment collection device.

- i. Direct the runoff from the site through a soil-specific polymer mixing system, and over a series of riprap to slow the velocity of the water.
- ii. Open the channel up into a dispersion delta. This dispersion field should be covered in jute and applied with the site-specific polymer powder, to provide a surface for the particles to adhere to. The velocity of the water in the channel determines the size of the delta; it needs to be large enough that the velocity is reduced to 0.5 ft/sec.

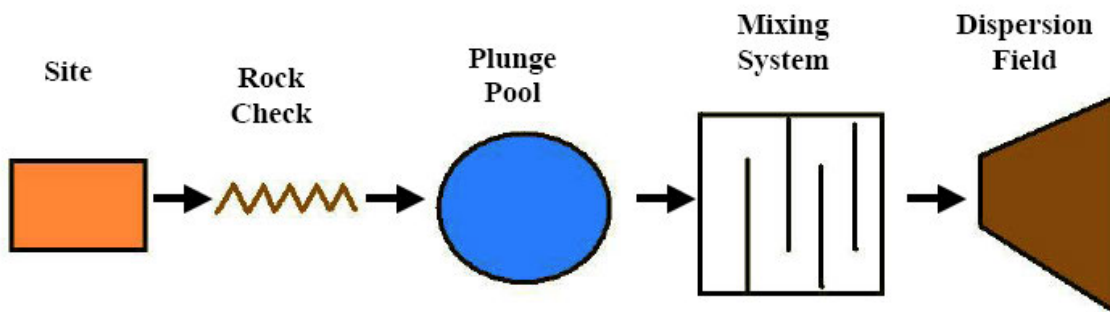
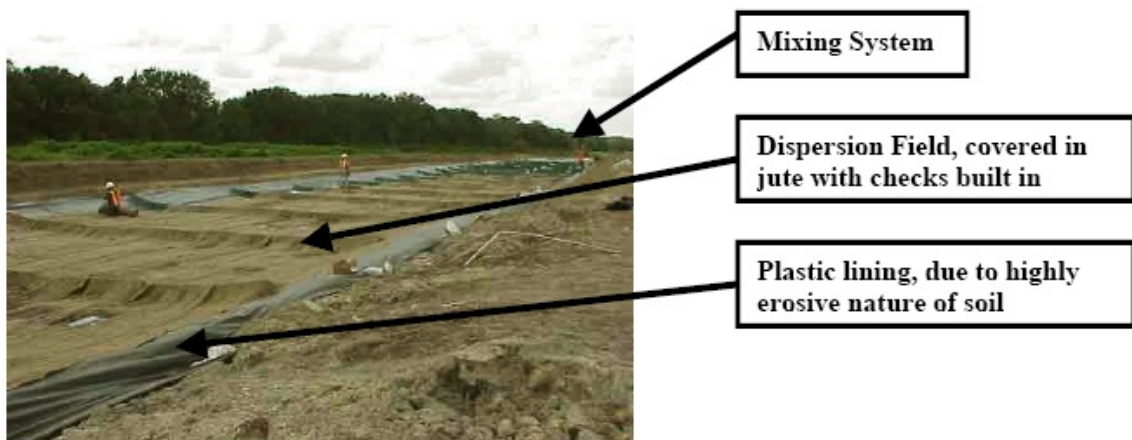

Figure AIII-22: Polymer-enhanced Particle Collection.

b) Baffle Grids

A series of panels made of jute or similar fabric, to collect fine particles from turbid water after polymer reaction. The panels can be treated with a site-specific polymer as well for short-term increased performance to aid in further water clarification.

- i. This device is for maintaining water quality, not sediment control.
- ii. Pump or drain into a plunge pool surrounded by a riprap apron.
- iii. Direct the overflow from the plunge pool or fore bay/ grit pit to collect the heavier sediment.
- iv. Direct the overflow from the grit pit through a series of baffle panels, made of jute fabric and applied with polymer powder.
- v. The baffle grids are used in conjunction with a mixing system or polymer logs in storm drains, where turbid water is treated with polymer and then sent through the baffle grids. Alternately, this can be used in conjunction with existing stormwater structures. Secure the appropriate polymer logs into the storm drain system, with adequate mixing over each log, while allowing for the correct mixing time before discharge to the grid. Cinder blocks or rubble can be placed into the open ditch or trough to facilitate mixing.

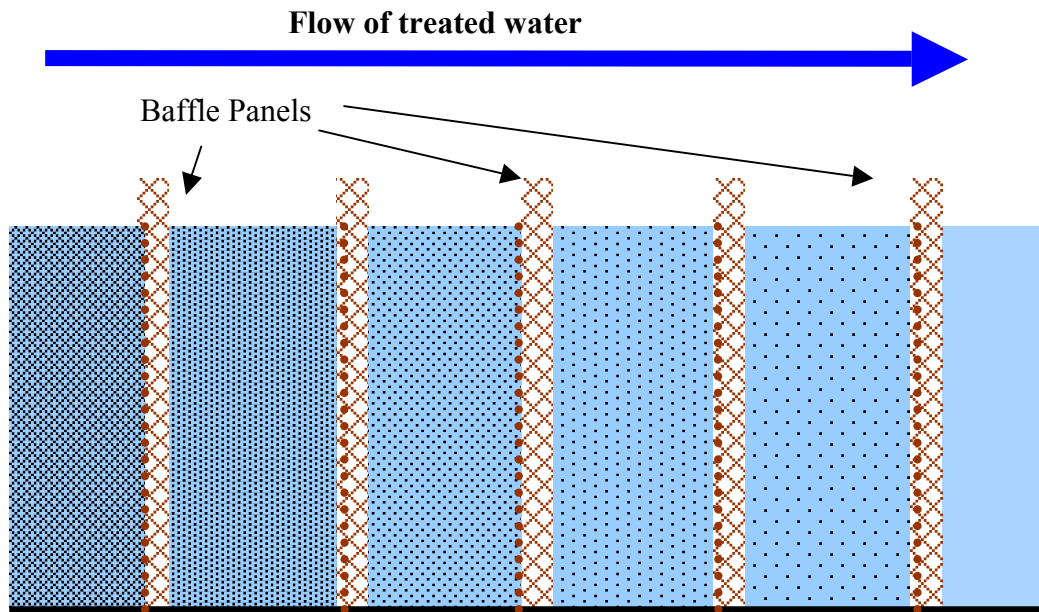

Figure AIII-23: Polymer-enhanced Baffle Grids.



Limitations: It is to be noted that this application is for “polishing up” the water after it has undergone maximum treatment to remove sediment. This application is not adequate water clarity control by itself, it is intended to be used in conjunction with other stormwater treatment systems.

Figure AIII-24: Polymer-enhanced Baffle Grids in the Field.

c) Particle Curtains

A series of curtains made of jute and coconut fabrics attached to floats to be used in wet ponds and flowing waterways to collect fine particles from turbid water after polymer reaction. Particle curtains are to be used in conjunction with site-specific polymers upstream of the curtains.

- i. Secure the site-specific polymer far enough upstream to allow for appropriate mixing with the turbid water. Make sure that the water can flow over and around the polymer logs, adding mixing structures if needed to increase turbulence around the polymer logs to facilitate proper mixing.
- ii. Install the particle curtains in lines perpendicular to the flow across the sediment pond or waterway.
- iii. The particle curtains will float.
- iv. Inspect and repair or replace the particle curtains as required.



Figure AIII-25: Polymer-enhanced Particle Curtains.

d) Wattle or Check Collection System

To be used for in-stream particle collection. The wattles are placed perpendicular to the flow to create a series of checks that will trap sediment reacted with the site-specific polymer upstream. This can be improved by covering the wattles and the ditch line with jute fabric and applying the appropriate site-specific polymer powder. The polymer reacts with the suspended particles, binding them together and adhering them to the matting.

- i. Secure the appropriate site-specific polymer logs in the ditch or stormwater system far enough upstream of the wattles to allow for adequate mixing to occur.
- ii. Place wattles perpendicular to the flow of water.
- iii. Cover with a layer of jute or coconut matting, secure with stakes or rocks.
- iv. Apply dry polymer powder to the matting cover, using a seed or fertilizer spreader. Application rate: 10-20 pounds of powder/acre.

Figure AIII-26: Polymer-enhanced Wattle and Check Collection Systems.

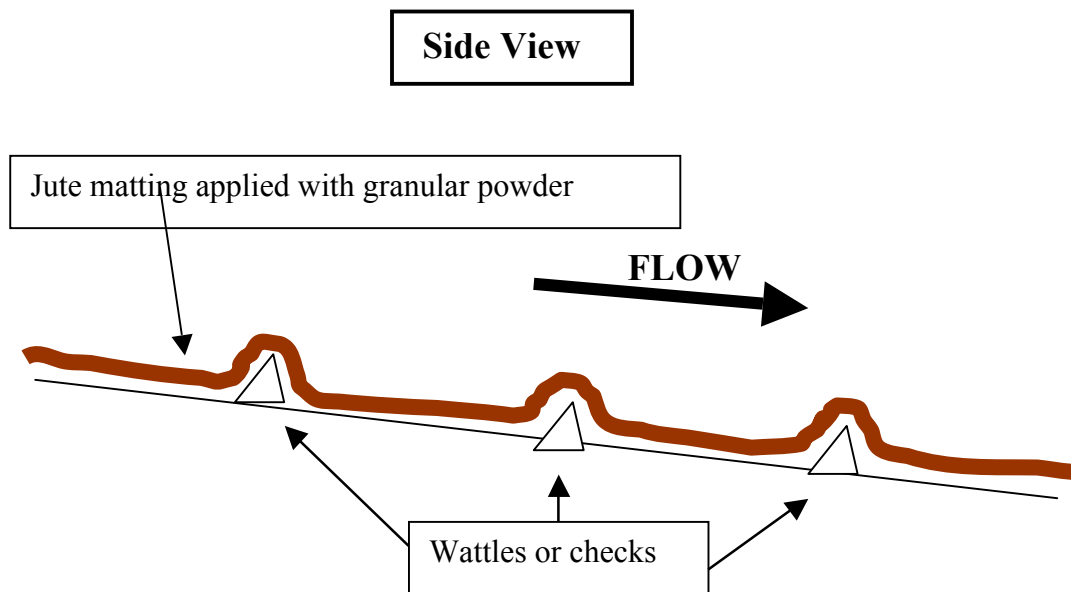

Polymer Log Enhanced Level Spreaders

Level spreaders are panels of organic fabric or silt fence, installed in lines across a sediment pond, perpendicular to the flow designed to increase settling time and increase the particle collection capabilities of the SCS. When used with site-specific polymer logs upstream within the runoff, the polymer log reacts with the colloidal clays, metals, and nutrients increasing particle size and decreasing settling time. This allows for very rapid settling time and greatly increased water quality.

- i. Secure the appropriate site-specific polymer logs in the stormwater system far enough above the sediment pond to allow for adequate mixing to occur.
- ii. Install lines of silt fence or organic panels perpendicular to the flow, in lines across the sediment pond, making sure they are as level as possible.
- iii. If using silt fence, use silt fence designed to allow at least 70 GPM/ft² of water to pass through it. FDOT approved silt fence or equivalent.
- iv. The heaviest of the reacted sediment will become trapped in the first cell, with smaller and smaller particles being trapped in each successive cell, as the water will be slowed upon hitting each level spreader.

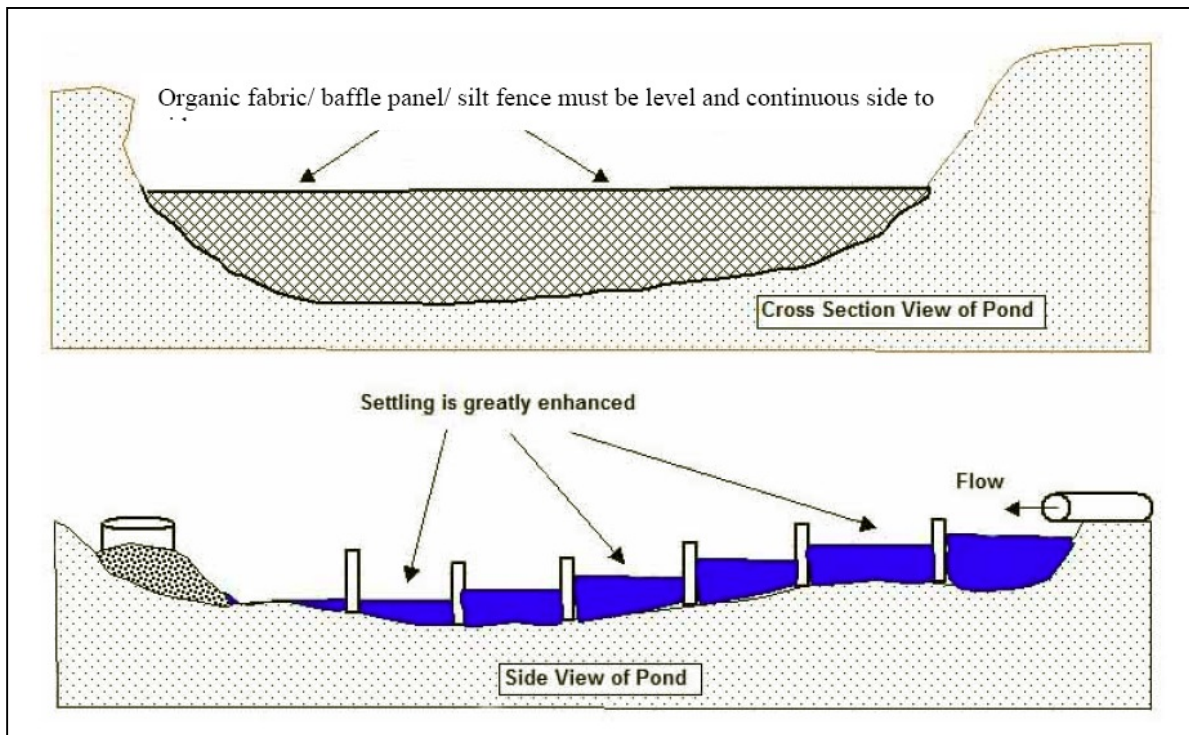

Limitations: There are limitations based on inflows. They must be sized to flow requirements on-site.

Figure AIII-27: Polymer-enhanced Level Spreaders.

Polymer Enhanced Mud/Sediment Removal

When designed properly, a sediment pond will collect and retain sediment. To maintain optimum efficiency, the sediment needs to be removed. Highly saturated soils can be messy and difficult to remove without spills or dripping. Adding a soil-specific polymer to the soil and mixing it in, binding the soil together, thickening the soil and making it easier to remove.

- i. Pump off the water from the pond, leaving the wet sediment behind.
- ii. Apply polymer powder to the sediment, and use the bucket of the removal equipment to stir it into the mud, to a maximum of 3 feet deep/ application.
- iii. Application rate: 50 pounds of polymer powder/ 100-200 cubic yards. This rate may vary with clay/organic type and content.
- iv. Allow 10-20 minutes for the polymer to react with the soil, the more mixing you do, the less time this will take.
- v. The polymer will cause the sediment to thicken, making it easier to remove without liquid spills or dripping.
- vi. The thickened sediment can then be used as a topsoil amendment to improve vegetation establishment. This material is not suitable for use as a structural fill.



Figure AIII-28: Polymer-enhanced Mud and Sediment Removal.

Polymer Enhanced Dust Suppression

a) Packed Dirt roads or traffic-ways

- i. Application rate: 0.75 – 1.5 gallons of polymer emulsion/ 3000 gallons of water/ 1 acre coverage. (No less than 3000 gallons of water should be used, do not exceed 1.5 gallons of emulsion/ 1500 gallons of water)
- ii. Emulsion additions are limited by high viscosity, do not exceed 3.0 gallons emulsion/ 3000 gallons of water.
- iii. Spraying device with a mechanical agitator, mixing apparatus or hydraulic recirculation is best.
- iv. Equipment should be prepared for polymer use by treating with surfactant to prevent buildup of polymer within the machinery, especially at nozzles and spraying points.
- v. Add the polymer emulsion slowly to the water to prevent clumping and poor performance.
- vi. Allow 2-3 minutes of mixing time before spraying the site.
- vii. Once completed, wash out all equipment used to spray polymer to prevent polymer residue from building up and reducing efficiency.



Figure AIII-29: Polymer-enhanced Dust Suppression.

ALUM

USE OF ALUM FOR SEDIMENT CONTROL

WHAT IS ITS PURPOSE?

- To remove suspended solids and pollutants by enmeshment and absorption onto alum.
- To collect flocs of suspended sediments in runoff and store within sediment basins or ponds.

WHERE AND HOW IS IT COMMONLY USED?

- Alum is injected into the flow stream containing turbid discharge to be treated.
- The injection is controlled using a variable speed chemical pump to feed alum at multiple treatment points.
- Alum is more effective in treatment of discharge that comes in contact with lime rock.
- The treatment process has to be carefully monitored.

WHEN SHOULD IT BE INSTALLED?

- While construction activities are occurring.
- After construction activities are completed.

WHERE AND WHEN SHOULD IT NOT BE INSTALLED?

- Alum treatment requires close monitoring of dosage and overdosing may be harmful.
- Where other compounds may violate toxicity requirements.
- Alum may lower pH and elevate levels of Al^{+3}

WHAT NEEDS TO BE INSPECTED?

- Inspect control units prior to forecast rain, daily during extended rain events, after rain events, weekly during the rainy season, and at two-week intervals during the non-rainy season.
- Alum control operational units are equipped with automatic feeders for low rate. These feeders must have alarms to alert operators of failure events. Inspection is needed to remedy such failed systems.

WHAT MAINTENANCE ACTIVITIES CAN BE EXPECTED?

- Deposition of sediments from the use of alum treatment may require periodic sediment removal from the sediment basin or ponds in order to maintain normal functions.

NOTES

1. There are four types of aluminum coagulants – Aluminum Sulfate (ALUM), Aluminum Chloride, Poly Aluminum Hydroxychloride and Alum/Polymer Blends (Floc Logs).
2. The use of alum in sediment control and treatment within an erosion and sediment control plan will require the use of a sediment pond or sediment basin. The alum precipitate formed during coagulation of runoff from the erosion-related activities can be allowed to settle in receiving water bodies or collected in sediment basins.
3. In a typical treatment system, alum is injected into the flow on a flow-proportioned basis so that the same dose of alum is added regardless of the flow rate. A variable speed chemical metering pump is typically used as the injection pump. If the initial laboratory testing indicates that the addition of alum to the target runoff flow will reduce pH levels to undesirable levels, a buffering agent, such as sodium aluminate ($Na_2Al_2O_4$) or sodium hydroxide ($NaOH$) can be injected along with the alum to maintain desired pH levels. A separate metering system and storage tank will be necessary for the buffering agent.
4. Once alum has been identified as an option for the project, extensive laboratory testing must be performed to verify the feasibility of alum treatment and to establish process design parameters. The feasibility of alum treatment for a particular construction activity related runoff stream is typically evaluated in a series of laboratory jar tests conducted on representative runoff samples collected from the project watershed area. Laboratory testing is an essential part of the evaluation process necessary to determine design, maintenance, and operational parameters such as the optimum coagulant dose required to achieve the desired water quality goals, chemical pumping rates and pump sizes, the need for additional chemicals to buffer receiving water pH, post-treatment water quality characteristics, floc formation and settling characteristics, floc accumulation, annual chemical costs and storage requirements, ecological effects, and maintenance procedures. In addition to determining the optimum coagulant dose, jar tests can also be used to determine floc strength and stability, required mixing intensity and duration, and determine design criteria for settling basins.
5. Since Al^{+3} can be a potentially toxic species, floc formation should be complete prior to discharging the treated runoff into the receiving waterbody (Harper, 1990). Al^{+3} is virtually removed from the water column in 45-60 seconds after alum addition. Therefore, alum injection locations should be carefully selected to allow a minimum of 45-60 seconds of travel time after alum addition prior to reaching the receiving waterbody.

DUAL POLYMER SYSTEMS

Passive System with Pretreatment Sediment Pond Utilizing a Loose Material Dual Polymer System with Matting and Wattles

WHAT IS ITS PURPOSE?

To clean construction storm water from a pond using a passive system prior to discharging into a regulated water body

WHERE AND HOW IS IT COMMONLY USED? (SEE FIGURE DPS-1)

- On a stream of construction run off to treat the water prior to discharge
- Sedimentation pond utilizes natural gravitation settling. Polymer enhancement and outlet flow control allow for higher performance over gravitational settling alone.

WHEN SHOULD IT BE INSTALLED?

- Before construction activities begin
- While construction activities are occurring
- To treat water when larger amounts of sediment loads are present
- As a pre-treatment for secondary treatment
- When discharging into a non-high quality water body

WHEN SHOULD IT NOT BE INSTALLED?

- When precise dosing of treatment chemicals is required
- When discharging into a high quality water body

WHAT NEEDS TO BE INSPECTED?

- Is there excessive sediment loading in the pond?
- Is the polymer material in good condition?
- What is the condition of the matting and wattles?
- Is the water exiting the system of sufficient clarity?
- Does the residual water test show any remaining polymer in the effluent water?

WHAT MAINTENANCE ACTIVITIES CAN BE EXPECTED?

- Removal of sediment from pretreatment pond
- Addition of polymer when necessary
- Cleaning or replacement of matting and/or wattles

NOTES

- Polymers in general should not be directly released into civic storm water systems or natural watercourses.
- Discharging water through vegetated areas or additional BMP's can further reduce turbidity.
- Filtrate can be collected for secondary treatment (optional).
- Biopolymers will completely degrade with enzymatic action.
- Dose rate of chemicals is dependent on flow rate and volume of water

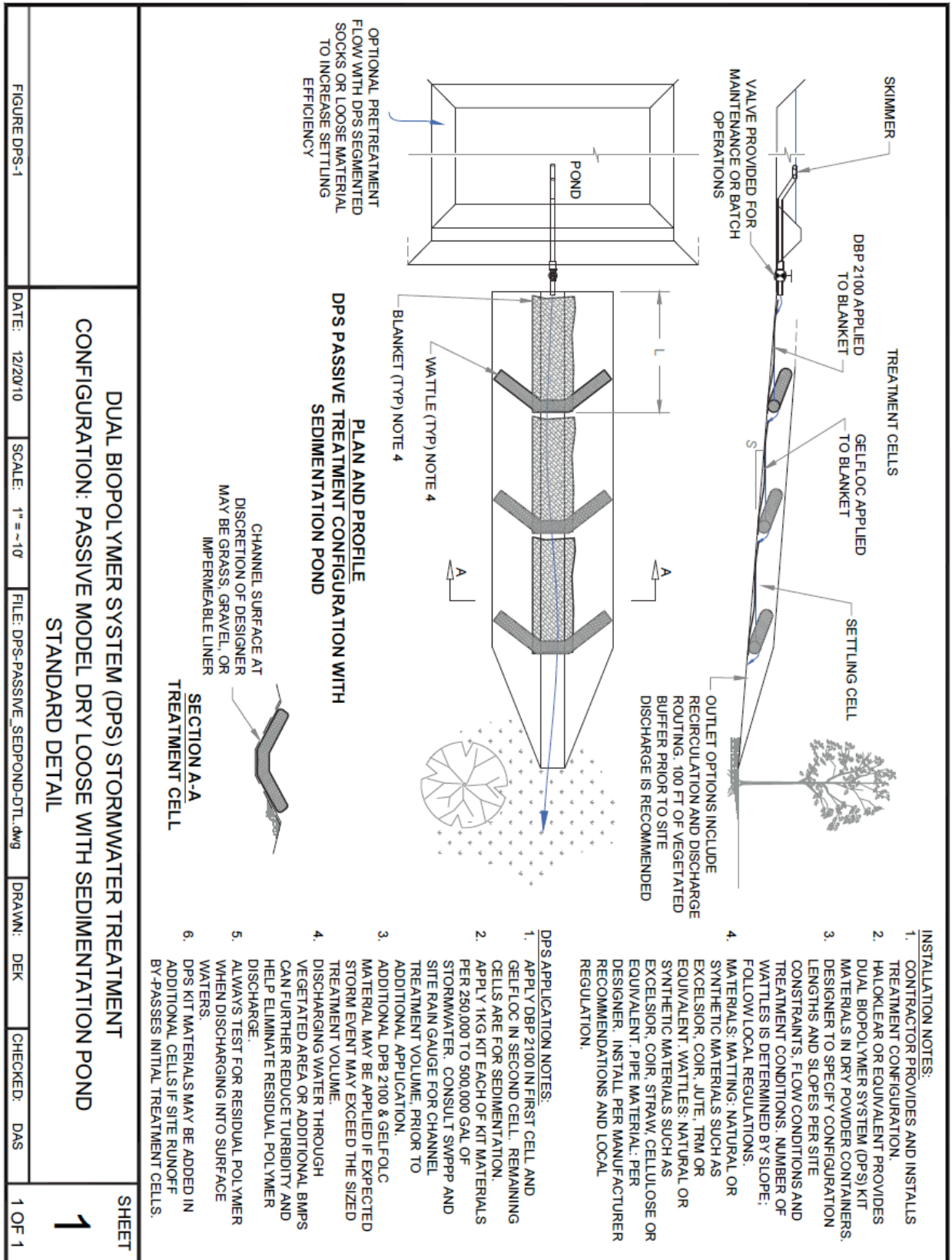

Figure AIII-30: Dual Biopolymer (DPS): Passive Dry use with Sedimentation Pond.

Passive Treatment of Turbid Water Utilizing a Dual Polymer System with Segmented Socks In Corrugated Pipe

WHAT IS ITS PURPOSE?

To clean construction storm water from a pond using a passive system prior to discharge into a regulated water body.

WHERE AND HOW IS IT COMMONLY USED? (SEE FIGURE DPS-9)

- On a stream of construction run off to treat the water prior to discharge

WHEN SHOULD IT BE INSTALLED?

- Before construction activities begin
- While construction activities are occurring
- To treat water stored on site
- After project completion to clean dirty water stored on site
- As pre-treatment for secondary treatment
- When discharging into a non-high quality water body

WHEN SHOULD IT NOT BE INSTALLED?

- When precise dosing of treatment chemicals is required
- When discharging into a high quality water body

WHAT NEEDS TO BE INSPECTED?

- Are the polymer socks in good condition?
- Are wattles still correctly installed or excessively blinded?
- Is the water exiting the system of sufficient clarity?
- Does the residual water test show any remaining polymer in the effluent water?

WHAT MAINTENANCE ACTIVITIES CAN BE EXPECTED?

- Changing of polymer socks
- Cleaning or replacement of wattles

NOTES

- Polymers in general should not be directly released into civic storm water systems or natural watercourses.
- Discharging water through vegetated areas or additional BMP's can further reduce turbidity.
- Biopolymers will completely degrade with enzymatic action.
- Dose rate of chemical is dependent on flow rate and volume of water. See approximate flow/dose table on attached drawing.

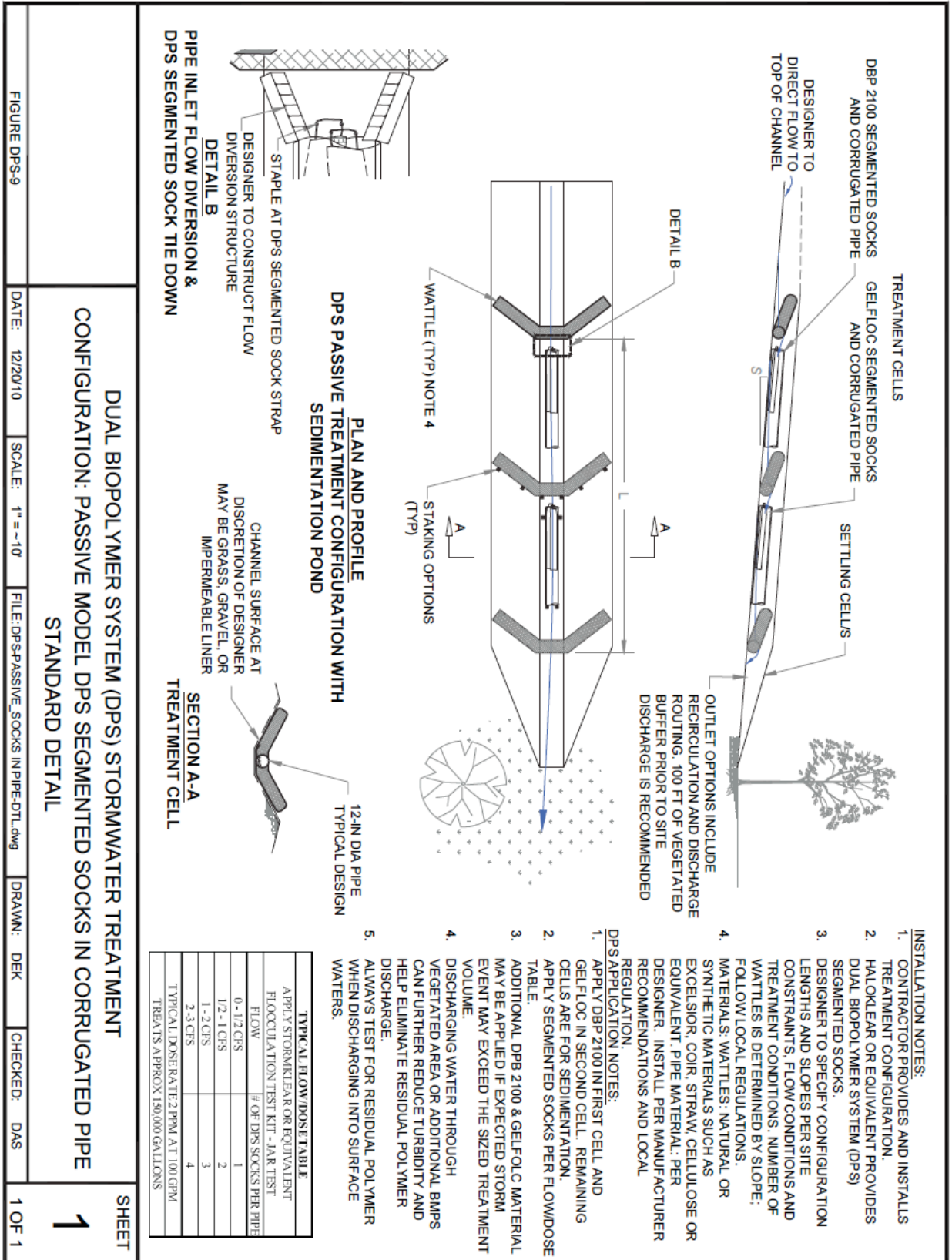

Figure AIII-32: Dual Biopolymer (DPS): Segmented Socks in Corrugated Pipe.

Passive Treatment of Turbid Water Utilizing a Dual Polymer System with Segmented Socks and Pipe on a Slope Drain

WHAT IS ITS PURPOSE?

To clean construction storm water prior to discharge into a regulated water body

WHERE AND HOW IS IT COMMONLY USED? (SEE FIGURE DPS-4)

- On a stream of construction run off to treat the water prior to discharge
- To convey and treat turbid water using site slope without creating further erosion

WHEN SHOULD IT BE INSTALLED?

- Before construction activities begin
- While construction activities are occurring
- To treat water stored on site
- As enhancement to typical slope drain application
- As pre-treatment for secondary treatment
- When discharging into a non-high quality water body

WHEN SHOULD IT NOT BE INSTALLED?

- When precise dosing of treatment chemicals is required
- When a slope to create proper flow is not available

WHAT NEEDS TO BE INSPECTED?

- Are the polymer socks in good condition?
- Is the effluent water from the pipe of sufficient clarity?
- Does the residual water test show any remaining polymer in the effluent water?

WHAT MAINTENANCE ACTIVITIES CAN BE EXPECTED?

- Changing of polymer socks

NOTES

- Polymers in general should not be directly released into civic storm water systems or natural watercourses.
- Discharging water through vegetated areas or additional BMP's can further reduce turbidity.
- Filtrate can be collected for secondary treatment (optional).
- Biopolymers will completely degrade with enzymatic action.
- Dose rate of chemical is dependent on flow rate and volume of water. See approximate flow/dose table on attached drawing.

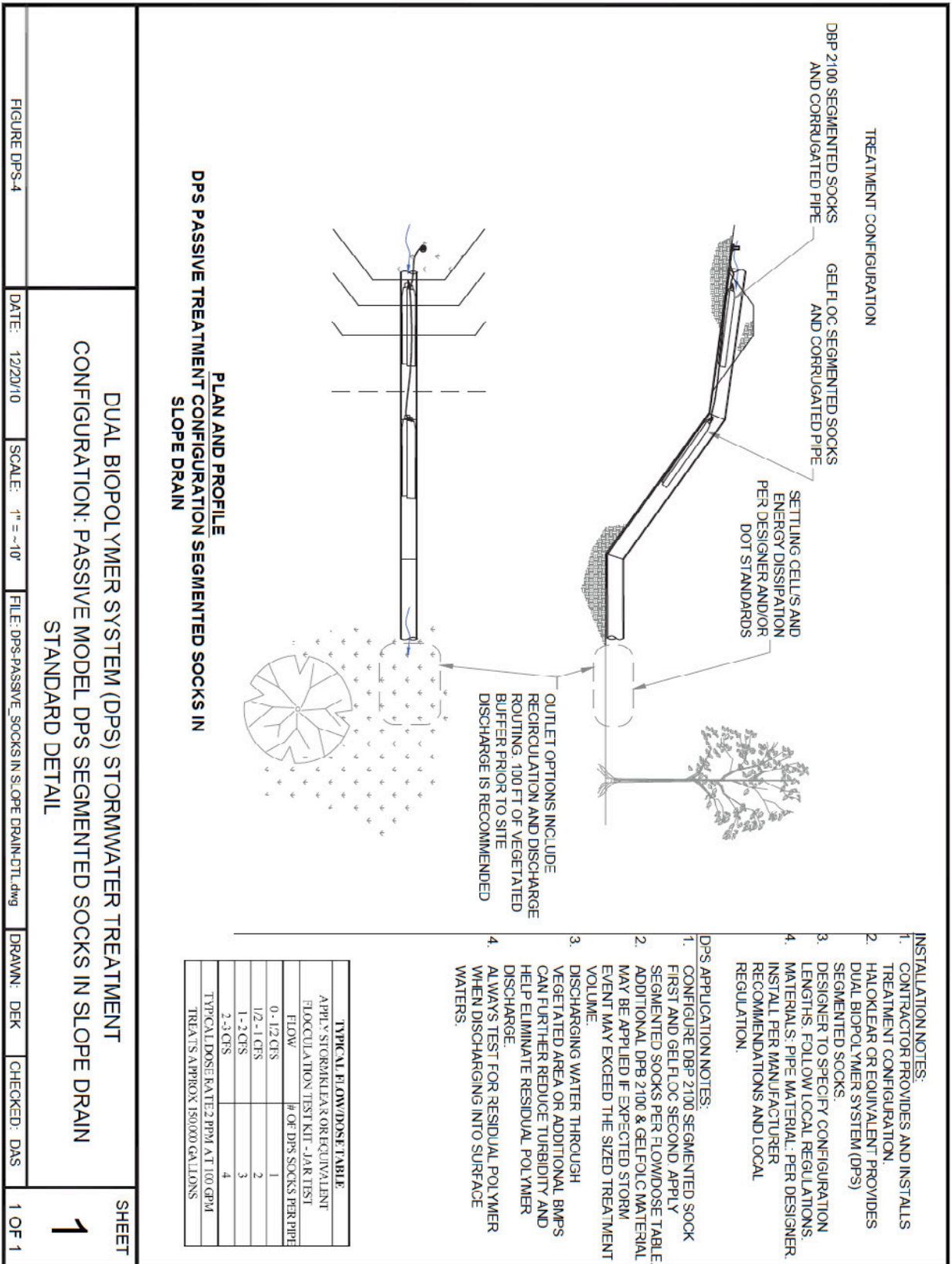

FIGURE DPS-4

DATE: 12/20/10

SCALE: 1" = -10'

FILE: DPS-PASSIVE SOCKS IN SLOPE DRAIN-DTL.dwg

DRAWN: DEK

CHECKED: DAS

1 OF 1

SHEET

1

Semi-Passive Treatment of Turbid Water Utilizing a Dual Polymer System and Dewatering Bags

WHAT IS ITS PURPOSE?

To clean construction storm water from a pond using a semi-passive system prior to discharge into a regulated water body

WHERE AND HOW IS IT COMMONLY USED? (SEE FIGURE DPS-6)

- On a stream of construction run off to treat the water prior to discharge

WHEN SHOULD IT BE INSTALLED?

- Before construction activities begin
- While construction activities are occurring
- To treat water stored on site
- To treat water when larger amounts of sediment load are present
- After project completion to clean dirty water stored on site
- When discharging into a non-high quality water body
- When high sediment content in influent water
- When space is limited

WHEN SHOULD IT NOT BE INSTALLED?

- When no method of pumping water is available
- When precise dosing of treatment chemicals is required
- When discharging into a high quality water body

WHAT NEEDS TO BE INSPECTED?

- Is there excessive sediment loading in the pond?
- Are the polymer socks in good condition?
- What is the condition of the dewatering bags?
- Is the effluent water from the system of sufficient clarity?
- Does the residual water test show any remaining polymer in the effluent water?

WHAT MAINTENANCE ACTIVITIES CAN BE EXPECTED?

- Clean sediment out of feed pond
- Check operation of water feed pump
- Changing of polymer socks
- Changing of dewatering bag

NOTES

- Polymers in general should not be directly released into civic stormwater systems or natural watercourses.
- Discharging water through vegetated areas or additional BMP's can further reduce turbidity.
- Dewatering bags should be placed on rock, geotextile fabric or vegetative surfaces.
- Biopolymers will completely degrade with enzymatic action.
- See table on drawing for flow/dose rates of polymer.

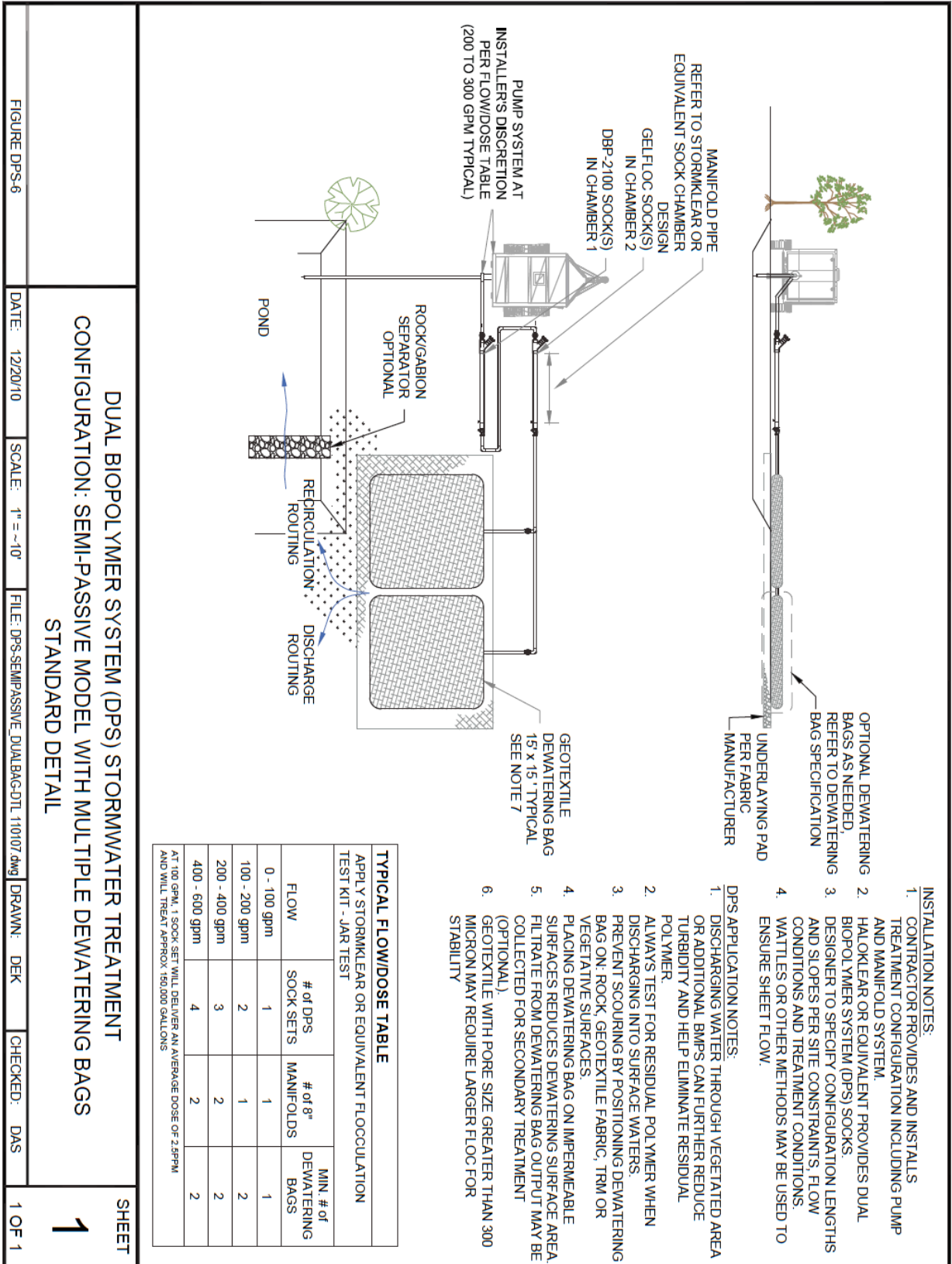

Figure AIII-34: Dual Biopolymer (DPS): Multiple Dewatering Bags.

Passive Treatment of Turbid Water Utilizing a Loose Material Dual Polymer System with Matting and Wattles

WHAT IS ITS PURPOSE?

To clean construction storm water from a pond using a passive system prior to discharge into a regulated water body.

WHERE AND HOW IS IT COMMONLY USED? (SEE FIGURE DPS-10)

- On a stream of construction run off to treat the water prior to discharge

WHEN SHOULD IT BE INSTALLED?

- Before construction activities begin
- While construction activities are occurring
- To treat water stored on site
- After project completion to clean dirty water stored on site
- As pre-treatment for secondary treatment
- When discharging into a non-high quality water body

WHEN SHOULD IT NOT BE INSTALLED?

- When precise dosing of treatment chemicals is required
- When discharging into a high quality water body

WHAT NEEDS TO BE INSPECTED?

- Is the polymer material in good condition?
- What is the condition of the matting and wattles?
- Is the water exiting the system of sufficient clarity?
- Does the residual water test show any remaining polymer in the effluent water?

WHAT MAINTENANCE ACTIVITIES CAN BE EXPECTED?

- Addition of polymer when/if necessary
- Cleaning or replacement of matting and/or wattles

NOTES

- Polymers in general should not be directly released into civic storm water systems or natural watercourses.
- Discharging water through vegetated areas or additional BMP's can further reduce turbidity.
- Biopolymers will completely degrade with enzymatic action.
- Dose rate of chemical is dependent on flow rate and volume of water

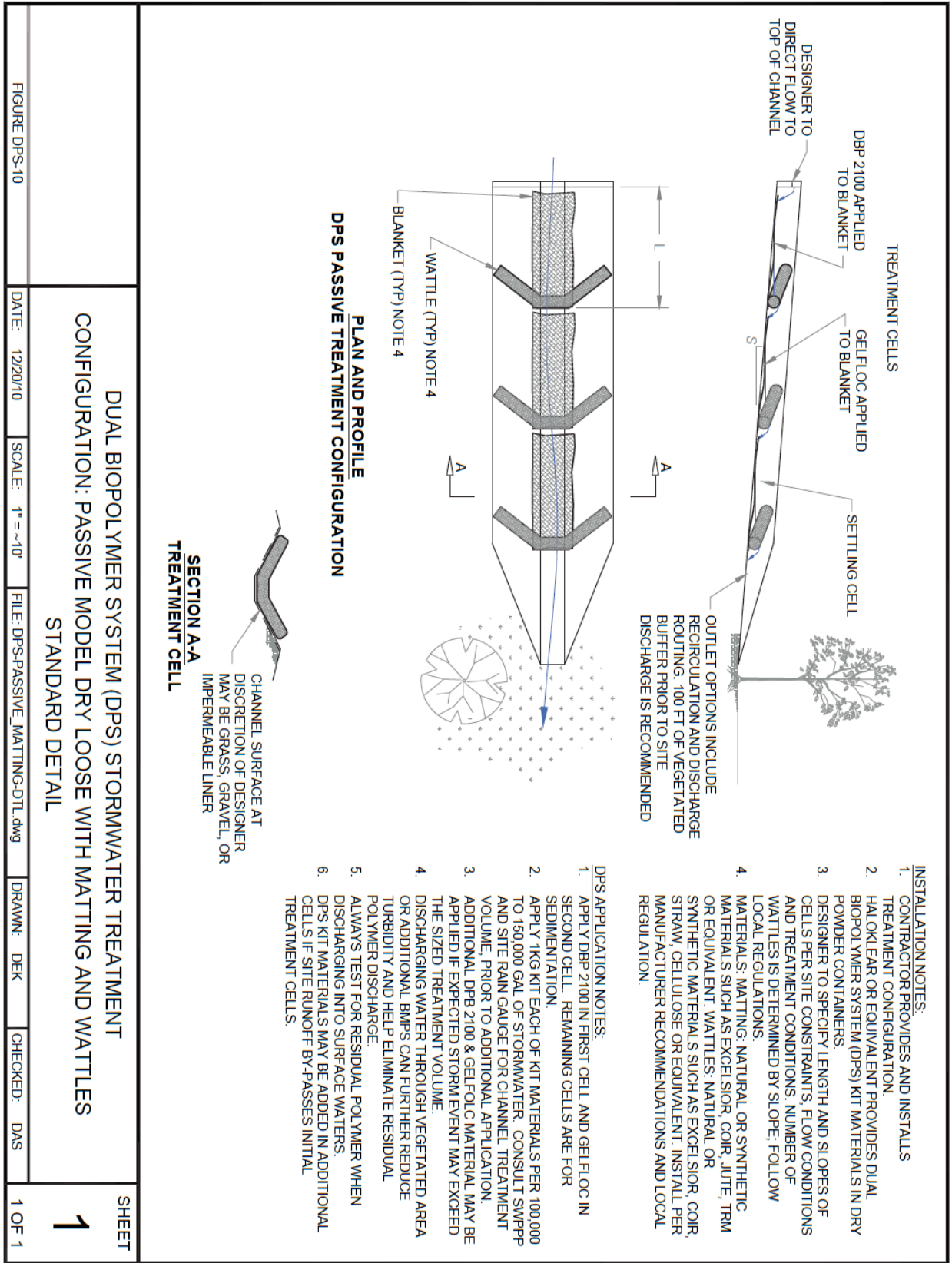

Figure AIII-35: Dual Biopolymer (DPS): with Matting and Wattles.

Semi-Passive Treatment of Turbid Water Utilizing a Dual Polymer System, Settling Tank and Wattles

WHAT IS ITS PURPOSE?

To clean construction storm water from a pond using a semi-passive system prior to discharging into a regulated and/or high quality water body

WHERE AND HOW IS IT COMMONLY USED? (SEE FIGURE DPS-3)

- On a stream of construction run off to treat the water prior to discharge

WHEN SHOULD IT BE INSTALLED?

- Before construction activities begin
- While construction activities are occurring
- To treat water stored on site
- To treat water when larger amounts of sediment load are present
- After project completion to clean dirty water stored on site
- For discharge into high quality water bodies

WHEN SHOULD IT NOT BE INSTALLED?

- When no method of pumping water is available
- When precise dosing of treatment chemicals is required

WHAT NEEDS TO BE INSPECTED?

- Is there excessive sediment loading in the collection pond?
- Is the pump operating correctly?
- Are the polymer socks in good condition?
- Are there excessive solids in the settling tank?
- Are the wattles in good condition?
- Is the effluent water from the system of sufficient clarity?
- Does the residual water test show any remaining polymer in the effluent water?

WHAT MAINTENANCE ACTIVITIES CAN BE EXPECTED?

- Clean out solids from feed pond
- Routine maintenance of water feed pump
- Changing of polymer socks
- Remove solids from tank
- Changing or cleaning of wattles

NOTES

- Polymers in general should not be directly released into civic storm water systems or natural watercourses.
- Discharging water through vegetated areas or additional BMP's can further reduce turbidity.
- Biopolymers will completely degrade with enzymatic action.
- See table on drawing for flow/dose rates of polymer.

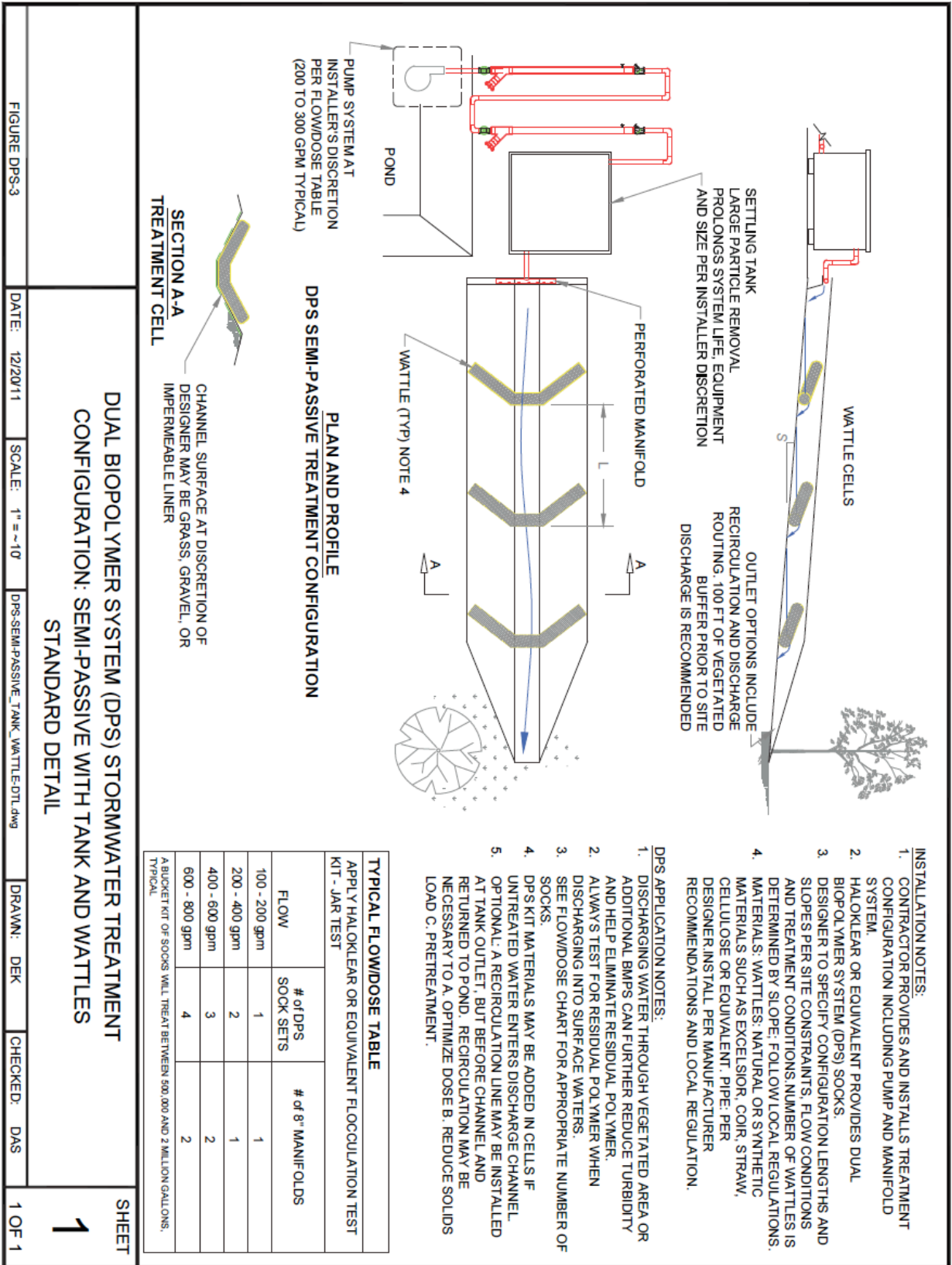

Figure AIII-36: Dual Biopolymer (DPS): with Tank and Wattles.

Semi-Passive Treatment of Turbid Water Utilizing a Dual Polymer System, Settling Tank and Dewatering Bags

WHAT IS ITS PURPOSE?

To clean construction storm water from a pond using a semi-passive system prior to discharging into a regulated and/or high quality water body

WHERE AND HOW IS IT COMMONLY USED? (SEE FIGURE DPS-5)

- On a stream of construction run off to treat the water prior to discharge

WHEN SHOULD IT BE INSTALLED?

- Before construction activities begin
- While construction activities are occurring
- To treat water stored on site
- To treat water when larger amounts of sediment load are present
- After project completion to clean dirty water stored on site
- When discharging into a high quality water body

WHEN SHOULD IT NOT BE INSTALLED?

- When no method of pumping water is available
- When precise dosing of treatment chemicals is required

WHAT NEEDS TO BE INSPECTED?

- Are the polymer socks in good condition?
- Are there excessive solids in the settling tank?
- What is the condition of the dewatering bags?
- Is the water exiting the system of sufficient clarity?
- Does the residual water test show any remaining polymer in the effluent water?

WHAT MAINTENANCE ACTIVITIES CAN BE EXPECTED?

- Routine maintenance of water feed pump
- Changing of polymer socks
- Removing of solids from settling tank
- Changing of dewatering bag

NOTES

- Polymers in general should not be directly released into civic storm water systems or natural watercourses.
- Discharging water through vegetated areas or additional BMP's can further reduce turbidity.
- Biopolymers will completely degrade with enzymatic action.
- See table on drawing for flow/dose rates of polymer.

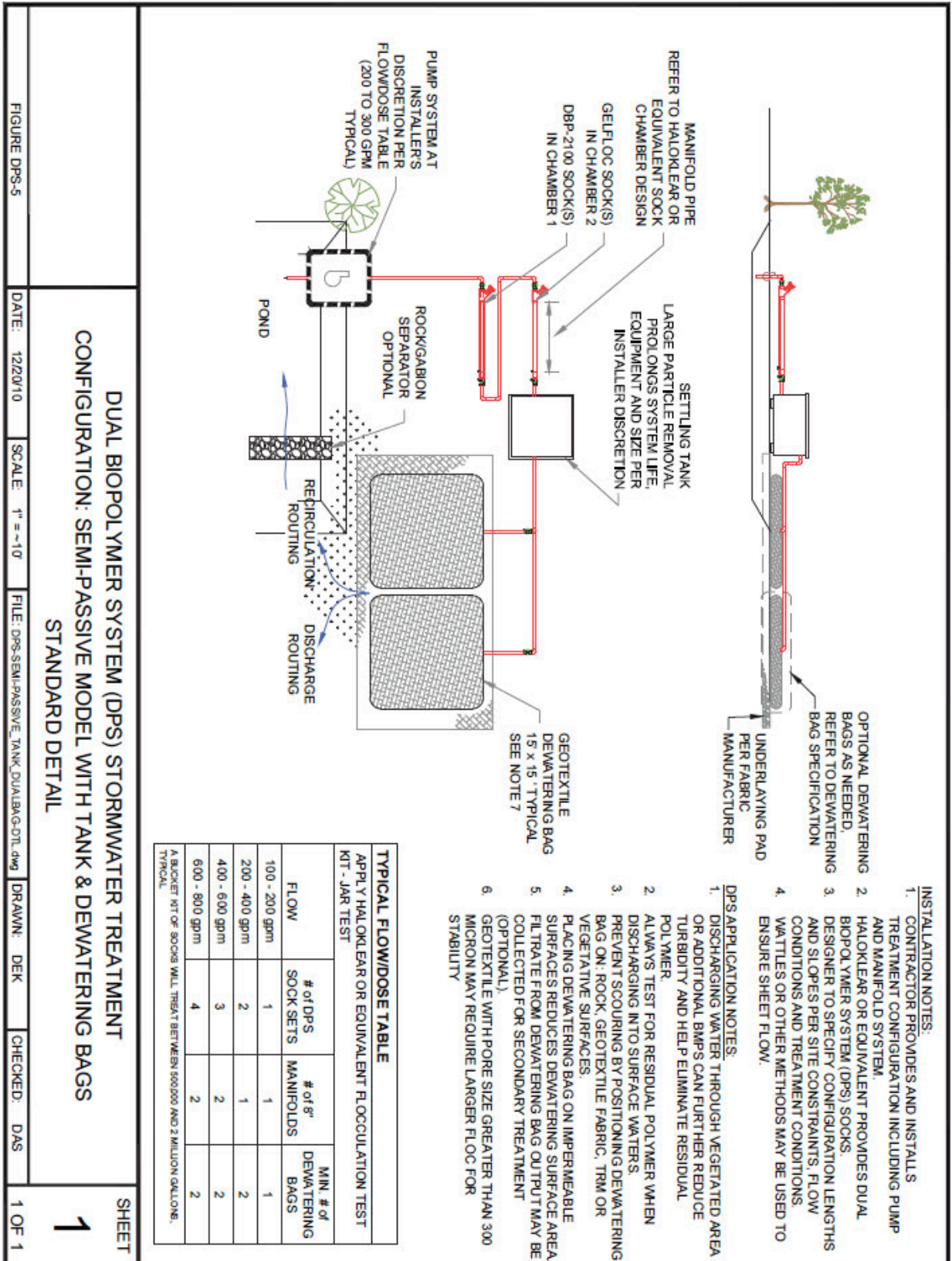

FIGURE DPS-5

DATE: 12/20/10

SCALE: 1" = -10'

FILE: DPS-SEMI-PASSIVE_TANK_DUALBAG-DTL.dwg

DRAWN: DEK

CHECKED: DAS

1 OF 1

DUAL BIOPOLYMER SYSTEM (DPS) STORMWATER TREATMENT CONFIGURATION: SEMI-PASSIVE MODEL WITH TANK & DEWATERING BAGS STANDARD DETAIL

SHEET **1**

Semi-Passive Treatment of Turbid Water Utilizing a Dual Polymer System, Tank,
Dewatering Bag and Wattle Channel

WHAT IS ITS PURPOSE?

To clean construction storm water from a pond using a passive system prior to discharge into a regulated water body.

WHERE AND HOW IS IT COMMONLY USED? (SEE FIGURE DPS-7)

- On a stream of construction run off to treat the water prior to discharge

WHEN SHOULD IT BE INSTALLED?

- Before construction activities begin
- While construction activities are occurring
- To treat water stored on site
- To treat water when very large amounts of sediment load are present
- After project completion to clean dirty water stored on site
- For discharge into high quality water bodies

WHEN SHOULD IT NOT BE INSTALLED?

- When no method of pumping water is available
- When precise dosing of treatment chemicals is required

WHAT NEEDS TO BE INSPECTED?

- Are the polymer socks in good condition?
- What is the amount of solids in settling tank?
- What is the amount of solids in dewatering bag?
- What is the condition of the wattles?
- Is the water exiting the system of sufficient clarity?
- Does the residual water test show any remaining polymer in the effluent water?

WHAT MAINTENANCE ACTIVITIES CAN BE EXPECTED?

- Routine maintenance of the water feed pump
- Changing of polymer socks
- Removal of solids from settling tanks
- Changing of dewatering bags

NOTES

- Polymers in general should not be directly released into civic storm water systems or natural watercourses.
- Discharging water through vegetated areas or additional BMP's can further reduce turbidity.
- Biopolymers will completely degrade with enzymatic action.
- See table on drawing for flow/dose rates of polymer.